

*Your Planning Guide  
to designing an  
archery facility  
on virtually any scale:*

*from a small  
Community Archery  
Range to a Full  
Service Archery  
Training Center.*

## Archery Terms

**Target Matt:** A foam or filled matt that holds arrows that are shot at the Target Matt.

**Target Face:** A sheet of paper, plastic sheeting or other material attached to the Target Matt. Target archery target faces are printed with concentric black, blue or multi colored circles. Target faces have five to 10 scoring rings. Each ring represents a scoring area of greater value nearer the center. Target faces may also represent animal shapes. Target faces range in size from sixteen inches to over four feet square.

**Target:** Shortened term for a target matt, target face or target face on a target matt, 3D animal shaped foam or otherwise filled target.

**Shooting Position, Station:** The location where the archer stands when shooting towards a target.

**Waiting Area:** Area for archers to stand by immediately prior to moving to the shooting position.

**Equipment Area:** Area where archers temporarily place their bows when not shooting.

**Archers Area:** Area where archers wait when not shooting

**Spectators Area:** Area for spectators and others to congregate when events prohibit sharing the archer's area.

**Safety Zone:** Area designated to provide reasonable clearance and separation from the archery.



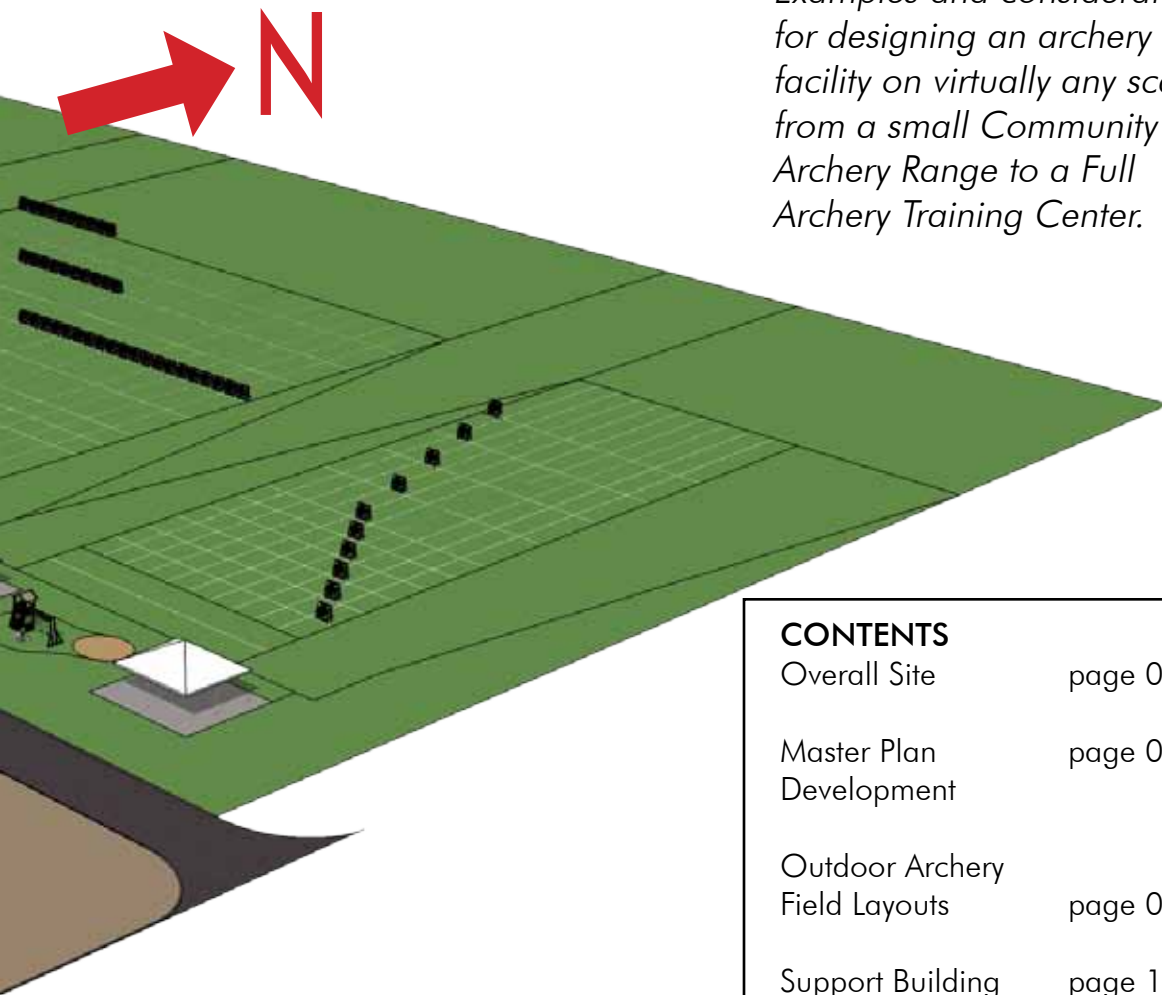

*Examples and considerations for designing an archery facility on virtually any scale, from a small Community Archery Range to a Full Archery Training Center.*

<b>CONTENTS</b>	
Overall Site	page 04
Master Plan Development	page 05
Outdoor Archery Field Layouts	page 06-09
Support Building	page 10
Indoor Range	page 11-13
APPENDIX Index	page 14
Archery Facility Categories	page 38-39

Designs and Guidelines created for Easton Foundations by--



www.spsplusarchitects.com

©2011 Easton Foundations

*Archery is a diverse sport ranging from a recreational activity, to an Olympic sport, to a self sufficiency skill. Archery outreach, education, programs, training and event facilities, with staff and equipment; provide the opportunity to be introduced to the sport as well as ongoing support.*

*This guide provides sample designs and general information for those who wish to develop an Archery Facility regardless of the size or complexity, as well as basic functional and design factors for local architects and engineers. Each feature includes a graphic, plan and narrative.*

*Archery facility requirements vary with each community. After the program goals are identified, this guide can provide a design professional (ie. Architect, Landscape architect, Engineer...) with introductory information to determine the size of the facility and assist with planning.*

*Location, property and/or facility search begins by determining viable locations that have the necessary attributes. Properties and facilities are reviewed for a variety of items including but not limited to:*

- *Size and configuration*
- *Location within the community*
  - *Community land use and master plan compatibility*
  - *Topography and slope, flood plain*
- *Adjacent property and compatible uses*
- *Nearby goods and services, food, retail*
- *Access and transportation*
  - *Vehicles, bicycles, pedestrians*
  - *Public transportation*
  - *Venue specific transportation (i.e. dedicated shuttle)*
- *Infrastructure and services*
  - *Water, domestic and fire protection*
  - *Sewer, storm and sanitary*
  - *Electricity, Natural gas, propane*
  - *Communications*
  - *Public services*
    - \* *Police, Fire, Medical*
    - \* *Refuse, maintenance, repair*

*Size of property and/or facility is based on the program goals and the facility space requirement to provide for the goals.*

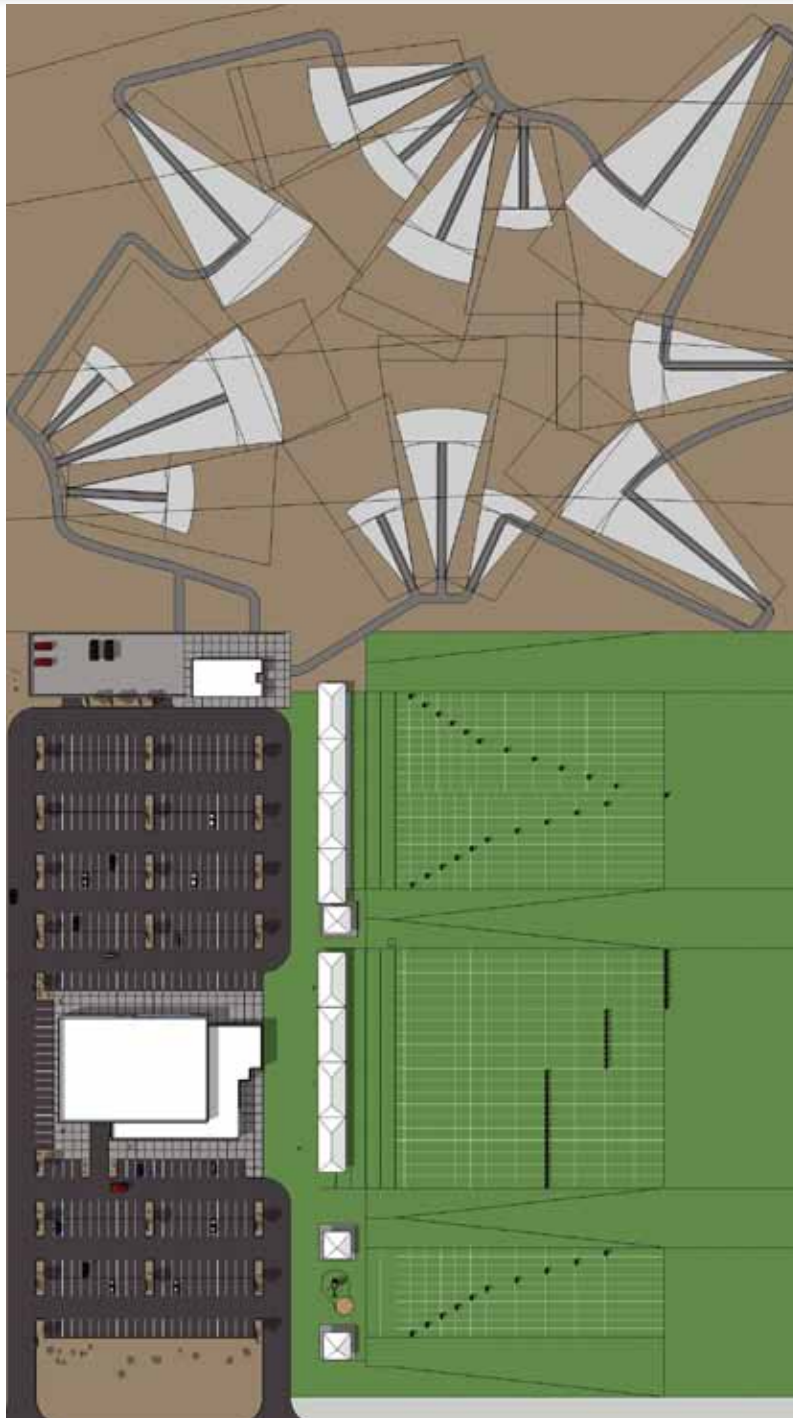

Discuss all the possibilities before deciding on a design and ultimate use of the site, be it a community park or future archery center.

All target archery fields should be oriented to shoot north for maximum usability.

## OVERALL SITE

Archery facilities provide for programs and activities. Main features include fields, courses and indoor ranges. Spaces may be limited to be able to serve only one function, or areas may be multi-purpose with other sports.

Safety is a primary focus. Functions that support that mission :

- Access by vehicles, bicycles, mass transportation and services
- Parking, private, buses, trailers and equipment
  - Comfortable ratio of 1.25 parking spaces per archer
  - Archer's equipment and accessories can be bulky. Ideally parking and unloading/loading areas should be near the range with aisles to the shooting areas.
- Accessibility, wheel chair, etc.
- Controlled access (barrier, fences, walls and gates)
- Safety area and set backs
- General security lighting
- Utility capacity and points of connect
- Landscaping and on site storm water retention
- Multi use by other activities
- Future phased sequence of additional improvements

Community planning, zoning and site engineering requirements and building codes govern development criteria.

Safety provisions are provided by physical configuration and by participant conduct. Safety zones or buffer area requirements are shown on the field diagrams. They may vary with the park layout. Fences or other barriers help to control area access. Archery industry research reveals that target archery is one of the safest sports in comparison to other sports (Archery Trade Association, Arrow Sport Insight, V3/07). When archers learn, practice, train and compete together; they follow a specific process that inhibits being put into harm's way.

All shoot their arrows from the shooting line or shooting station at the same time. When all have finished shooting, all retrieve their arrows together. Shooting resumes only when the range is clear.

Safety is a full time activity.

See Page 28 for Overall Site Plan

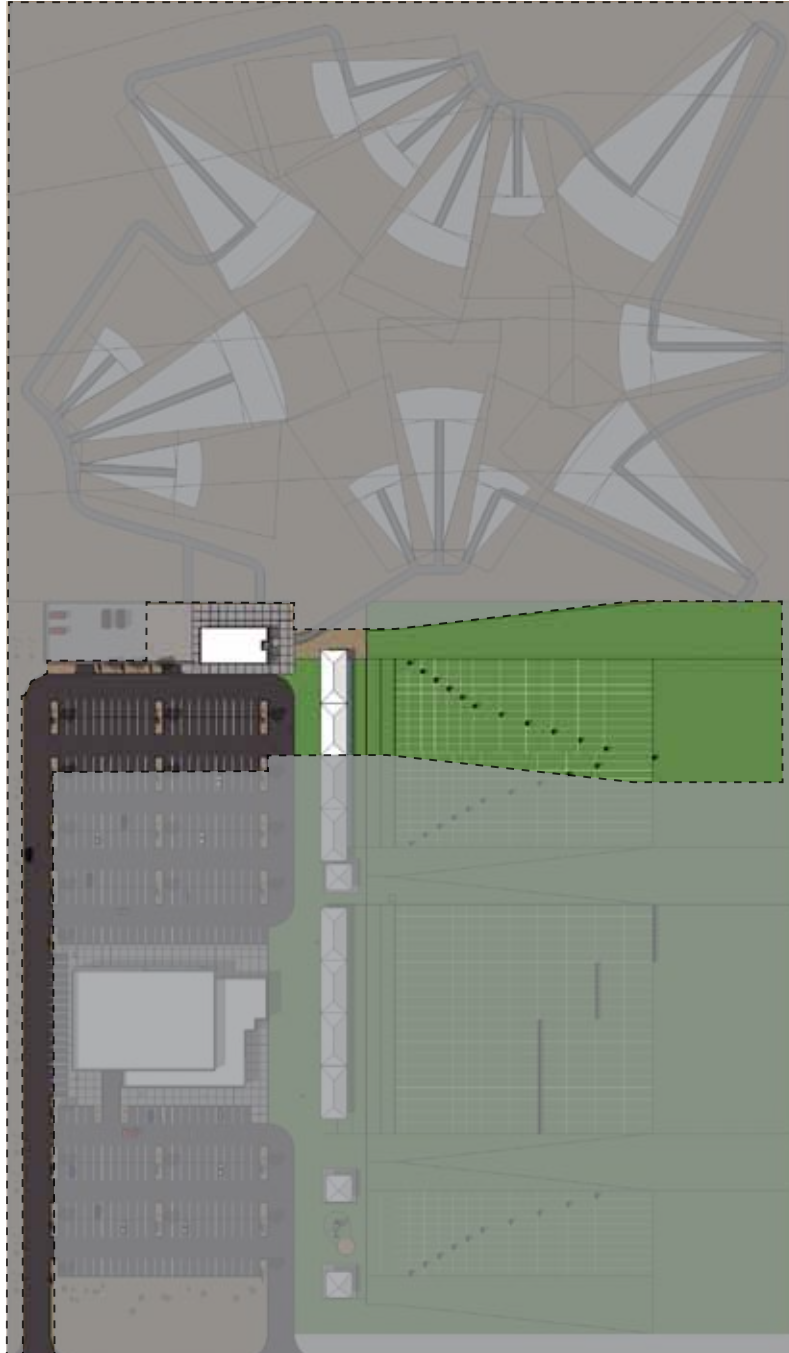

“Phase 1”  
Youth/Community  
Archery Field Only

Example Initial Development  
“Community Archery Field,  
Parking, Support Building”

## MASTER PLAN/INITIAL DEVELOPMENT

Master planning identifies facility requirements and envisions a physical layout. Master plan document may include a strategy to allow the master plan to be development in a series of phases.

This example depicts a community that envisions a comprehensive archery center beginning with a “Youth/Community Archery Field” facility. Phase one amenities include an entrance drive, parking lot with drop off, pick up area and archery field. Support facilities include a classroom, storage for the program and a club, rest-rooms, utility, office, work room and a shop/garage.

A fenced yard is provided for bulky items and secure outside storage. In this example, expanding the practice area & constructing the field course are in the next phase.

The master plan insures that the place of each amenity is compatible with future improvement and expansion. Initial planning with the help of knowledgeable archery programmer helps to avoid future conflicts. Master plans should be reviewed and updated periodically to address changes in wants and needs.

See Page 06 for Community Archery Field Description

See Page 10 for Support Building Description

See Page 29 for Master Plan/Initial Development Plan

## YOUTH/COMMUNITY FIELD

A dedicated Youth/Community Field is the key to the future of archery. It provides the place for parents to bring their children to practice archery in a wholesome environment dedicated to youth and families. Youth/Community fields are located away from "adult" areas so that the focus is on the youth and learning. Like the practice range, youth/community fields feature fixed distance targets. Practice field configuration concepts apply to the youth/community field. Shooting sequence, safety zones, barriers and fences help teach and provide for reasonable safety.

Distances may be either in meters or yards or both. The most popular yardages are 10 and 15. Popular meter distances are 18/20, 25 and 30. 40, 50, 60 and 70 meters are distances for more advanced youth.

Youth/Community field canopy and seating areas allow for family members to oversee and relax while their family takes part independently. A play area allows the youth archer and/or siblings to take a break away. Restrooms, drinking fountains and support functions should be nearby.

Youth/Community Fields may be designed to fit into a unique landscaping scheme or as part of a designated "Green Space."

Ranges and fields require planning, staff and equipment to serve a comprehensive archery program

See Page 30 for Youth/Community Field Plan

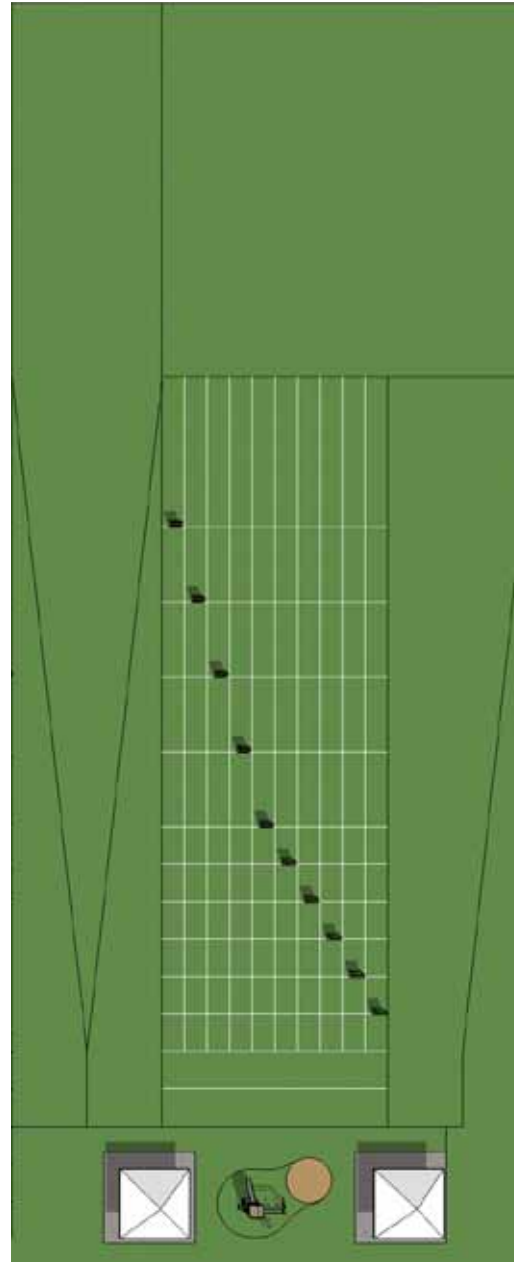
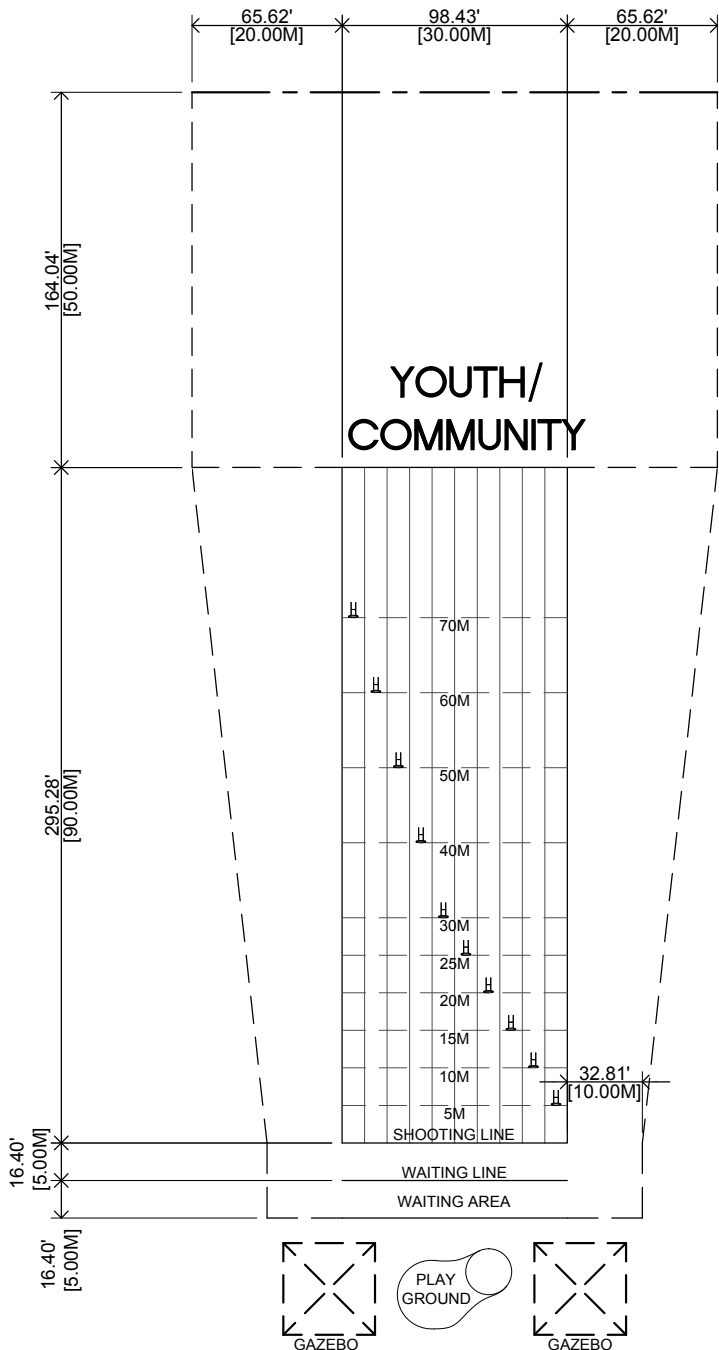

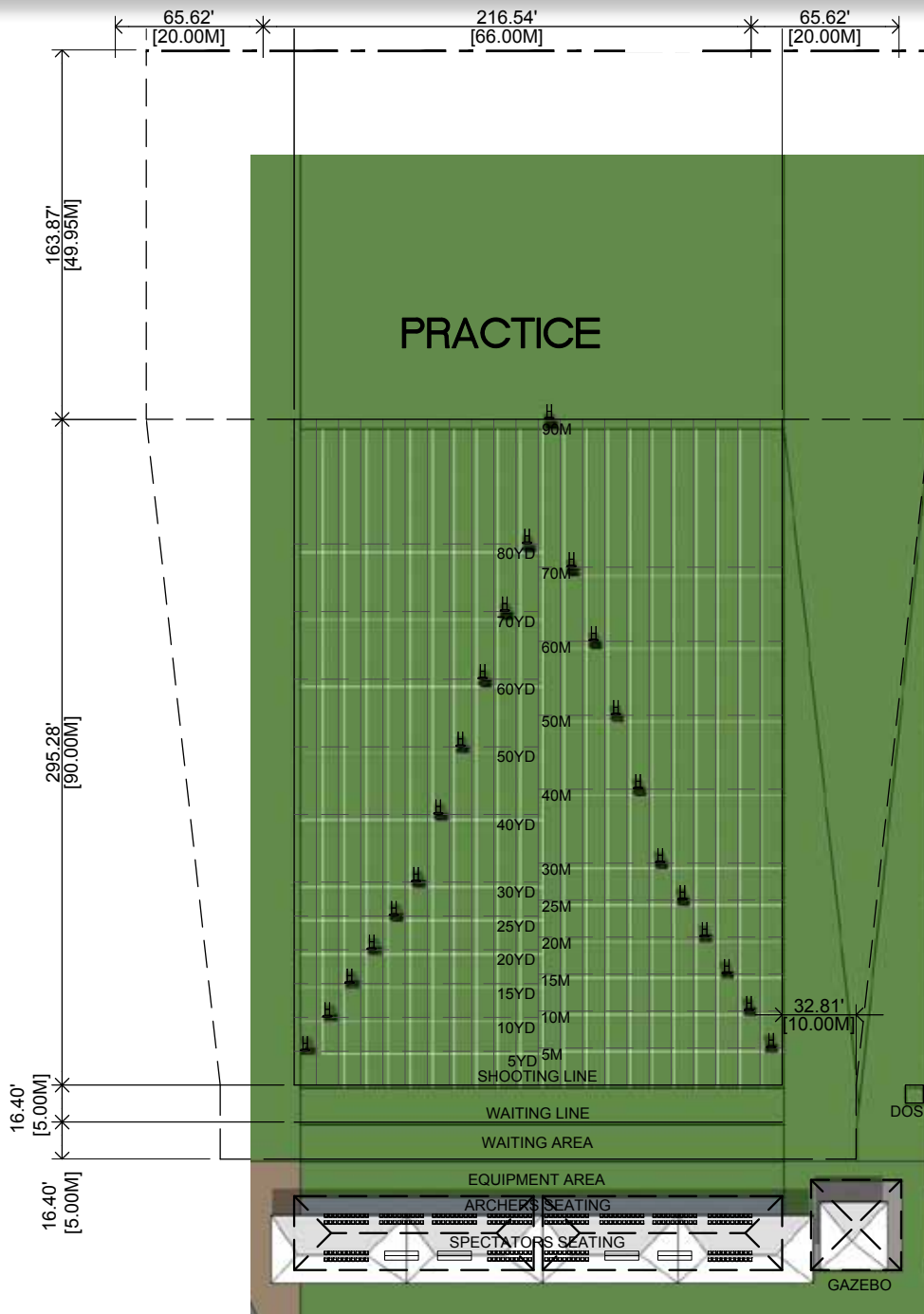

## PRACTICE FIELD

Provides for archers to learn, practice, train independently or as a group. Targets are placed at a variety of fixed distances in “meters” for international style and yards for national style. Fields are sloped minimally to allow for drainage. Targets should be spaced to allow multiple archers to shoot at a target simultaneously. Practice fields are used throughout the day, from dawn to dusk and at night if there are lights. Shooting sequence, safety zones, barriers and fences provide for safety. Safety zones may include visual barriers (fences, earthen berms) so that activities adjacent to the field do not distract from the shooting sequence. The side space for safety buffer extends to 10 meters to the side at the shooting line to a 20 meter width at 90 meters and then extends to 140 meters from the shooting line.

The space for an archer to shoot with a tripod mounted scope is approximately one meter (39 inches). Two archers may shoot at one target mat spaced at two meters (79 inches) simultaneously. 3 archers may shoot at a target spaced at three meters (118 inches). Popular target meter distances are 70 and 50 followed by 90, 30, 18 and 60. Yardage distances that are most popular for field archery and hunting are 10, 20, 30, 40, 50 and 60 yards followed by 5, 15, 25, 35, yards as well as 70 and 80 yards. Fields oriented to shoot from south to north are preferred to prevent shooting into the sun.

Practice ranges can be used as event fields by temporarily removing the fixed targets.

Space should be provided for waiting, equipment, and conversations. Canopies, tables, bbq’s, seating, restrooms and drinking fountains allow patrons to spend time at the field. Nearby storage, work room, classroom and offices allow for programs and education support and equipment tuning. Signage and bulletin boards inform and communicate. Electricity allows for the growing use of electronic devices and tools. Wi-Fi internet access is also popular.

Targets without target faces are often positioned a few feet away. These targets are referred to as “blank bales” and are used by archers to warm up.

See Page 31 for Practice Field Plan

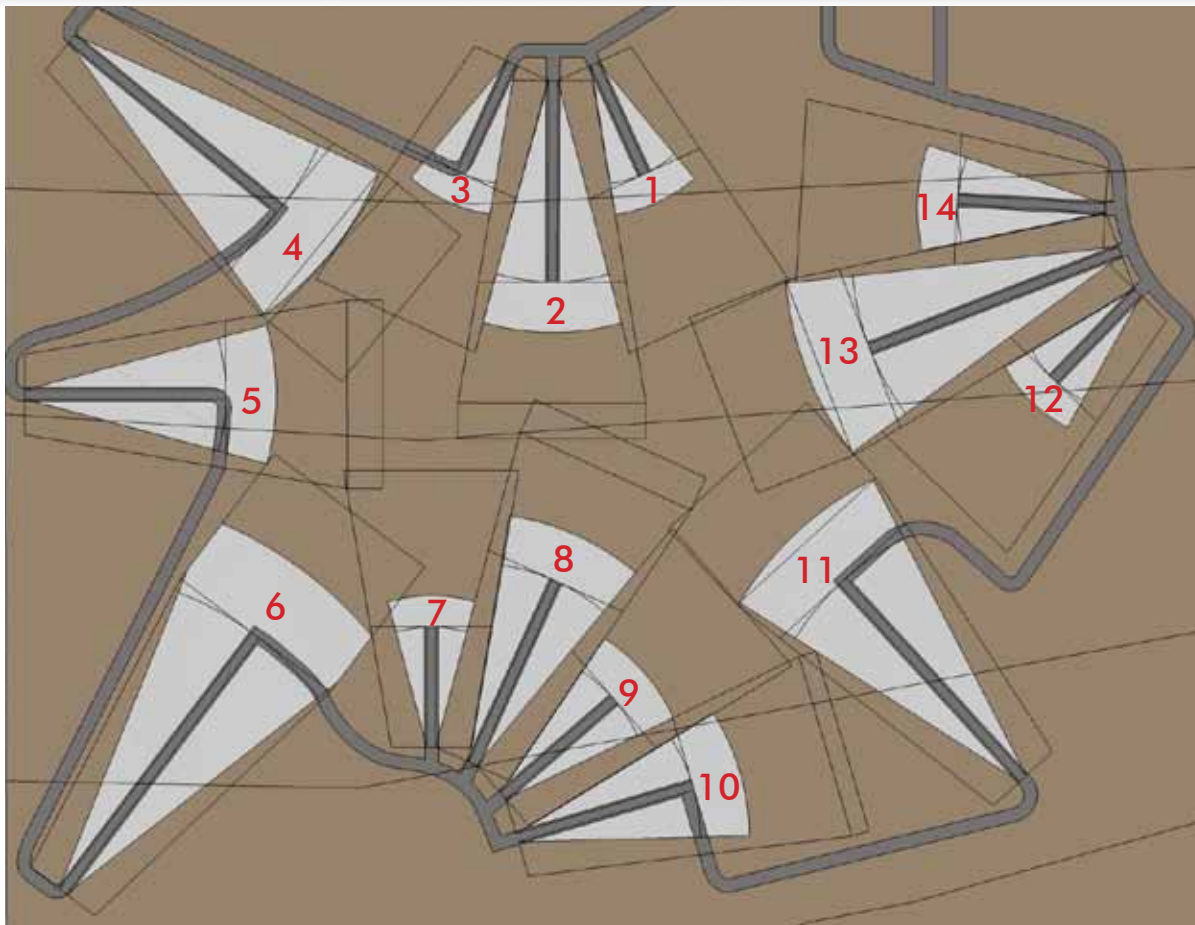

NOTE: This schematic is for demonstration only and should not be used as an actual site plan. Field courses are generally setup by archery range experts, and approved by their governing authority, taking advantage of terrain and other barriers to insure safety.

Quantity of Stations	Distance in Meters	Yards	Feet
4	27	30	90
2	33	36	108
1	41	45	135
3	45	50	150
3	60	66	198
1	72	80	240
Total: 14			

## FIELD ARCHERY

A field archery course consists of a foot trail with shooting positions or “stations” on the path. Stations should have space (about 6 feet) for two archers to shoot at one target. The archers shoot arrows at the target from the station, retrieve arrows and clear the area. They then move on to the next shooting station. Targets can be a concentric circle or an animal shape on “paper” on a target mat that retains the arrow or 3D (foam) animal shapes.

Courses are typically a minimum of fourteen (14) targets to allow for both International (World Archery/FITA, USA Archery) and national style (National Field Archery Association, Archery Shooter Association and other) target archery events. Competitions include known and unknown distance targets. Courses are typically unmarked distances and allow for targets to be moved to change the course. Known distance competitions are temporarily marked with a temporary sign. Safety zones vary with terrain and often natural features (creek banks, hills) are used to enhance the safety and archery experience. Variety is the key to a quality field archery course. More target stations allow additional variety. When space allows, multiple fourteen target field courses are ideal. Trail layouts include planning for rain water and water ways to minimize flooding, erosion and muddy shoes.

A field course requires approximately 1 acre (43,560 square feet) per station with target and associated dedicated and overlapping safety areas. Placement of the targets and pathways considers the archers view. 35 meters of clear space “behind” the target and 20 meters of clear space at each side of the target at 72 meters are common clearances. The field archery course safety zone template is a combination of space, angle and distance guide safety zone areas. The designer is encouraged to provide additional space as practical.

The following schedule of stations by target distance allows for common types of practice, training and competitions.

Field courses are lengthy. Maintenance, operation and oversight of the course is best conducted via a small off-road utility vehicle.

See Page 32-33 for Field Course Templates



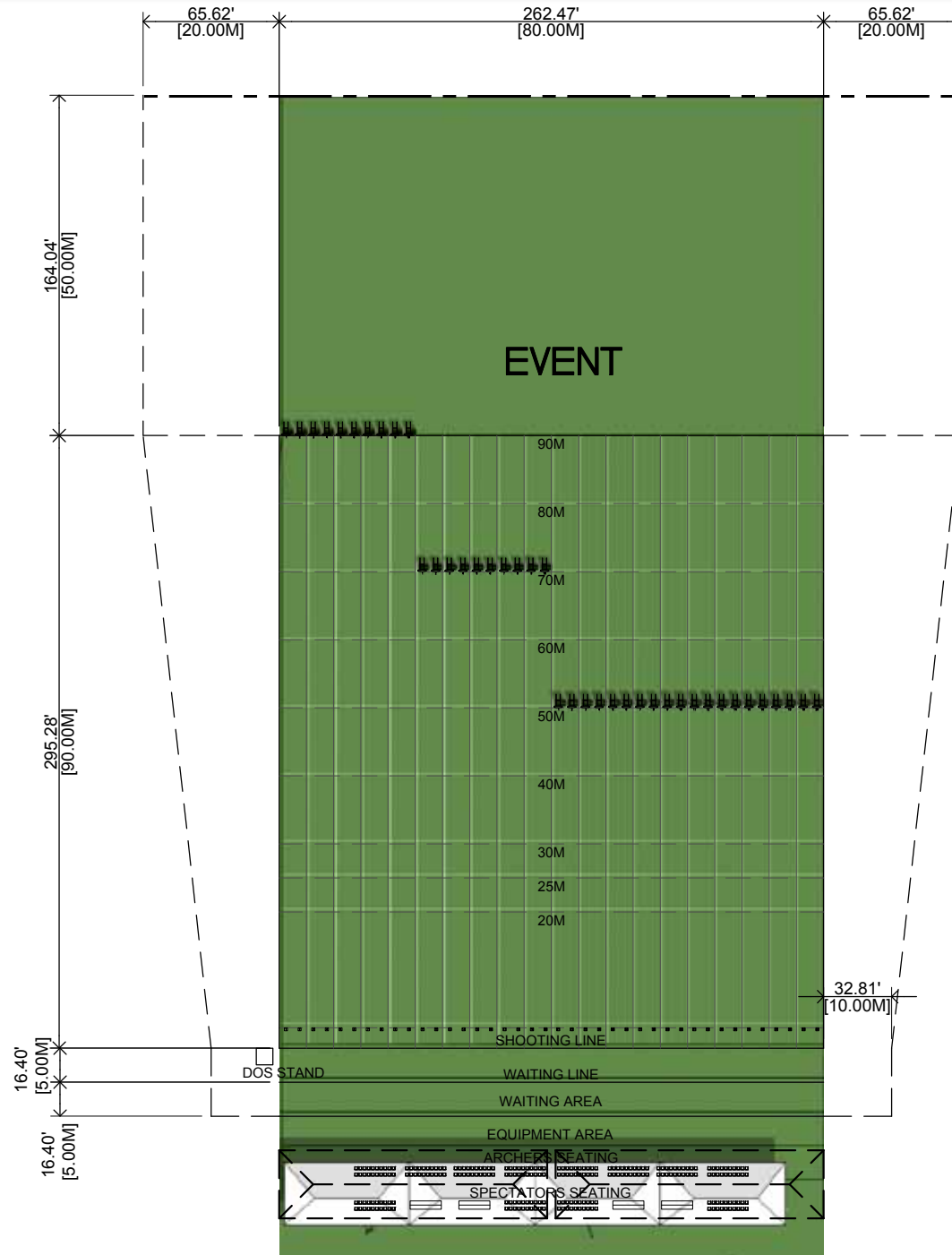

## EVENT FIELD

Provides for organized activities such as programs, camps and tournaments. The primary use of this field is for competition, including international and Olympic style archery. Practice field configuration concepts apply to the event field. Shooting sequence is highly controlled at tournaments. Safety zones, barriers and fences provide for safety in similar fashion to the practice and youth/community fields.

In addition to the amenities of the practice field, event fields have a temporary or permanent raised Director of Shooting (DOS) stand with canopy. Electricity is required at the DOS stand, on the field for timing and sound systems and in the archers and spectator area for tournament administration. Support spaces (restrooms, storage, offices, meeting rooms) should be nearby and sized to provide for the event functions.

Many functions such as first aid and registration maybe accommodated via temporary provisions until permanent facilities can be erected. Canopies are recommended over the seating area.

Competition and training target distances range from 5 yards to 90 meters (100 yards).

See Page 34 for Event Field Plan

## SUPPORT FACILITY

Along with the first Community Archery Range, the Support Facility may be the initial construction within a Community Archery Park project. Depending upon the Master Plan, this may be the only structure built, or the first of a series, depending on the extent of the overall archery complex. That said, it is designed to be self contained to house a number of storage and program capabilities. It is assumed that all archery shooting will take place outdoors.

Because of it's physical positioning on the site map, it can also function as a secondary structure to the main facility, and provide much needed storage and program space as the need grows.

Support facilities provide for the staff, equipment and materials needed to maintain the facility and grounds.

As shown in this example, Support Facility spaces may include restrooms, utility space, work room, garage/storage, office and a space for club or program storage. Classroom space is useful. Configuration for support services will vary greatly between facilities.

A fenced and paved yard provides for secure storage of vehicles, equipment (mowers, tractors) and target stands. A canopy may cover target mats.

In addition to a Support Facility, many sites use metal forty feet by eight feet wide "shipping containers" for bulk storage.

See Page 35 for Support Facility Floorplan

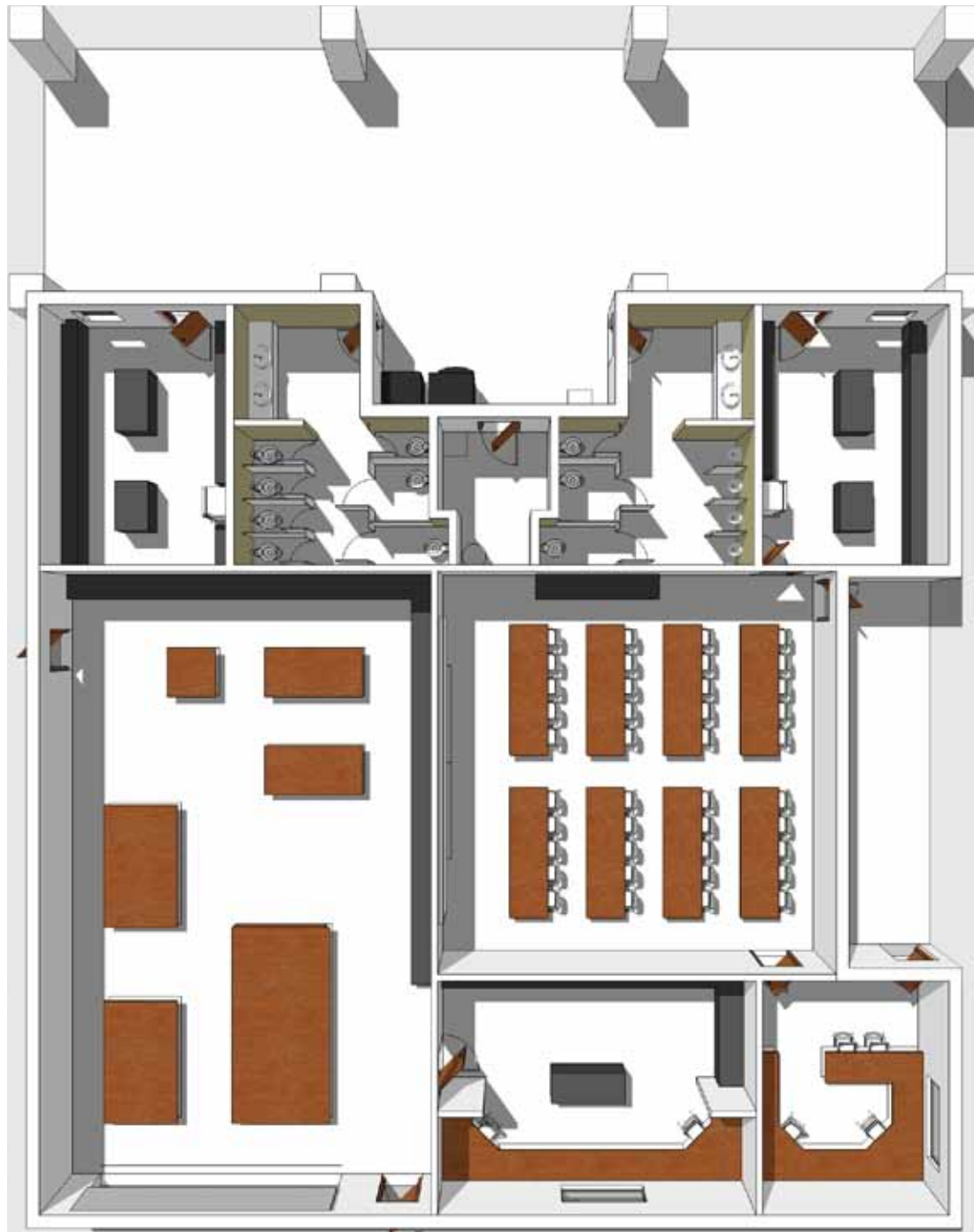

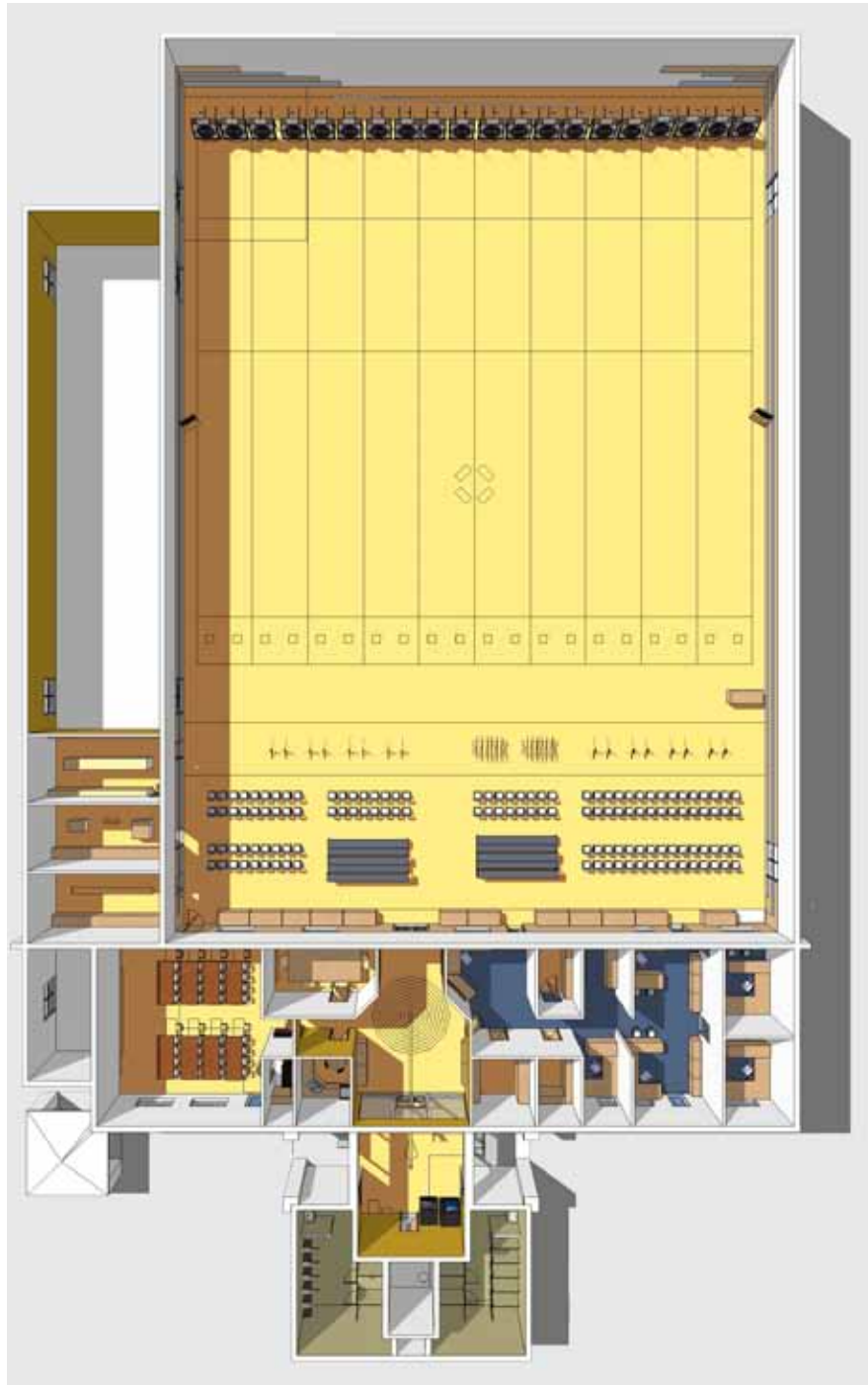

## INDOOR FACILITY

An indoor archery facility provides a safe, comfortable space to learn, train and compete. Indoor facilities are archer, family and spectator friendly on a year-round basis.

The main feature of this example of an Indoor Facility is the indoor archery range. The most popular indoor distance is 18 meters (20 yards). 25 meter competition is recognized internationally. Beginner programs will utilize 5, 10 and 15 yard distances. Indoor space is provided behind the targets for an arrow curtain to slow down arrows that miss the target. The back wall is typically lined with plywood to stop arrows that pass through the curtain. The 50 feet of space behind the shooting line provides for equipment, seating and benches. Additional space allows for longer distance shooting and/or more equipment or seating space.

The international standard for an archer's space on the shooting line is 80 centimeters (32 inches). Two archers can shoot at one target matt spaced at 64 inches simultaneously. The shooting position at each end should have extra space (perhaps 24") so that the archer does not feel confined against the wall. Plan for a 120 feet deep space the number of targets space width x 12 feet clear height space for an 18 meter range. 30 foot candles is an average lighting level. Air conditioning provides for year-round use.

Range equipment includes PA system, LED or video timer displays. Furnishings include chairs, bleachers, benches, mirrors, video equipment, video monitors, internet connection. Windows help staff monitor the ranges. Closed circuit video monitoring of the indoor range and outdoor ranges allows the staff to observe and record.

Indoor range support areas include storage, workshop, classrooms, conference rooms, administration restrooms, snack and beverage areas, entry and building support rooms. Separate work and storage areas allow for agencies and clubs to share the space and provide separate programs for full time facility usage. Each facility will have their own unique space requirements.

See Page 36-37 for Indoor Facility Floorplan

## INDOOR ARCHERY RANGE CROSS SECTION

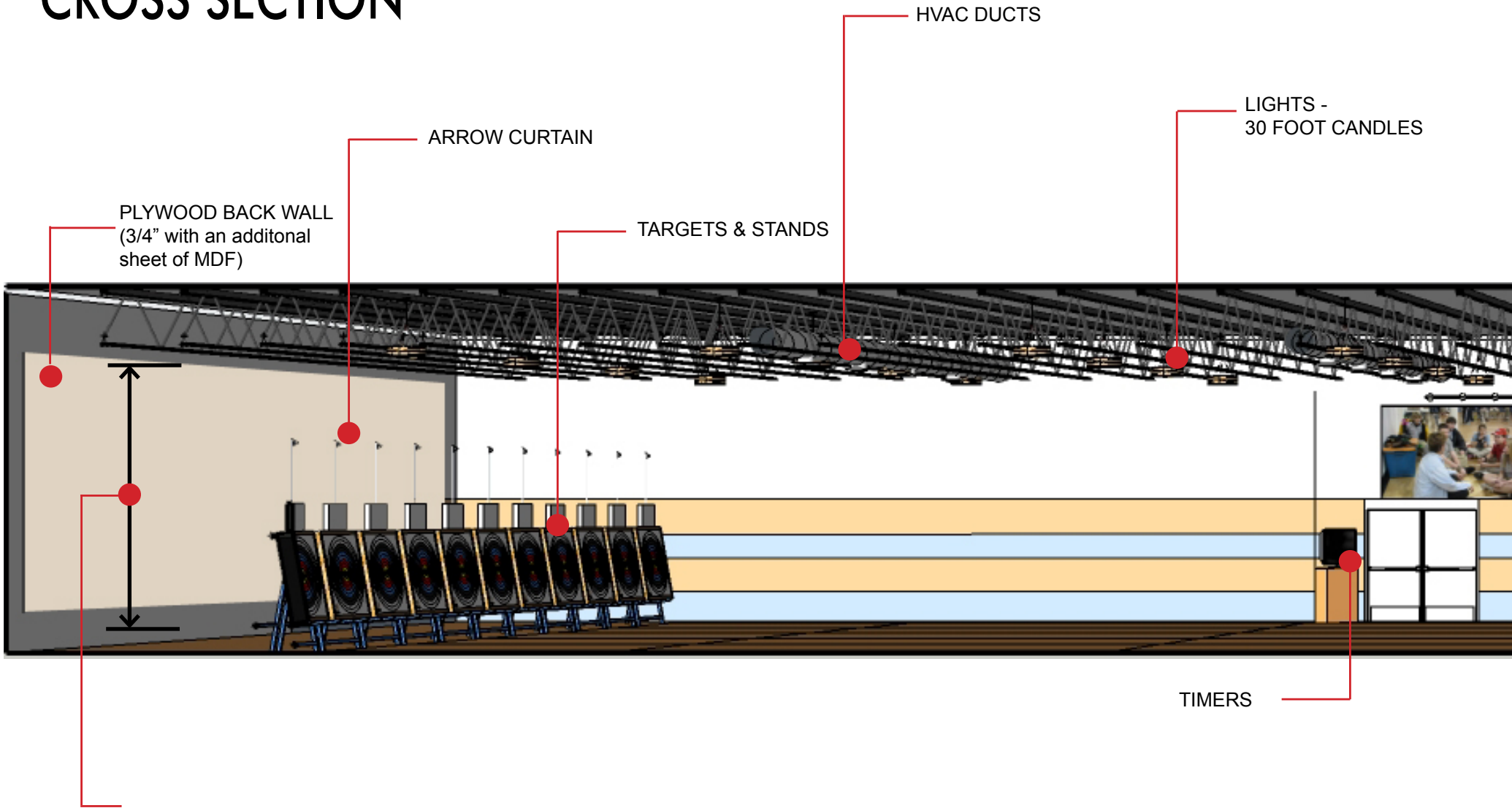

12' / 15' / 18' HEIGHT VARIES WITH DISTANCE

- 18M RANGE USES 12' HIGH CLR.
- 25M RANGE USES 15' HIGH CLR.
- 30M RANGE USES 18' HIGH CLR.

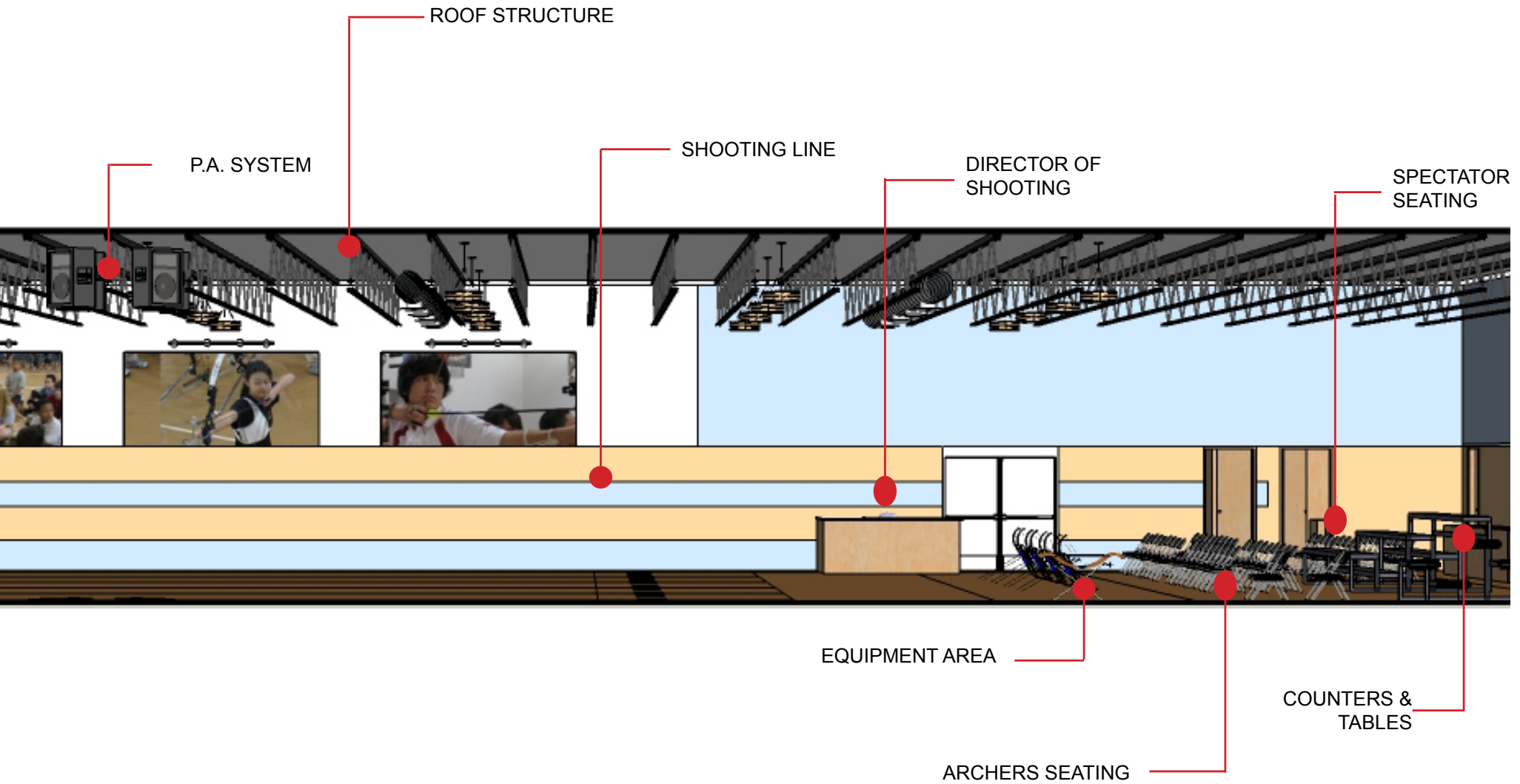

# APPENDIX INDEX

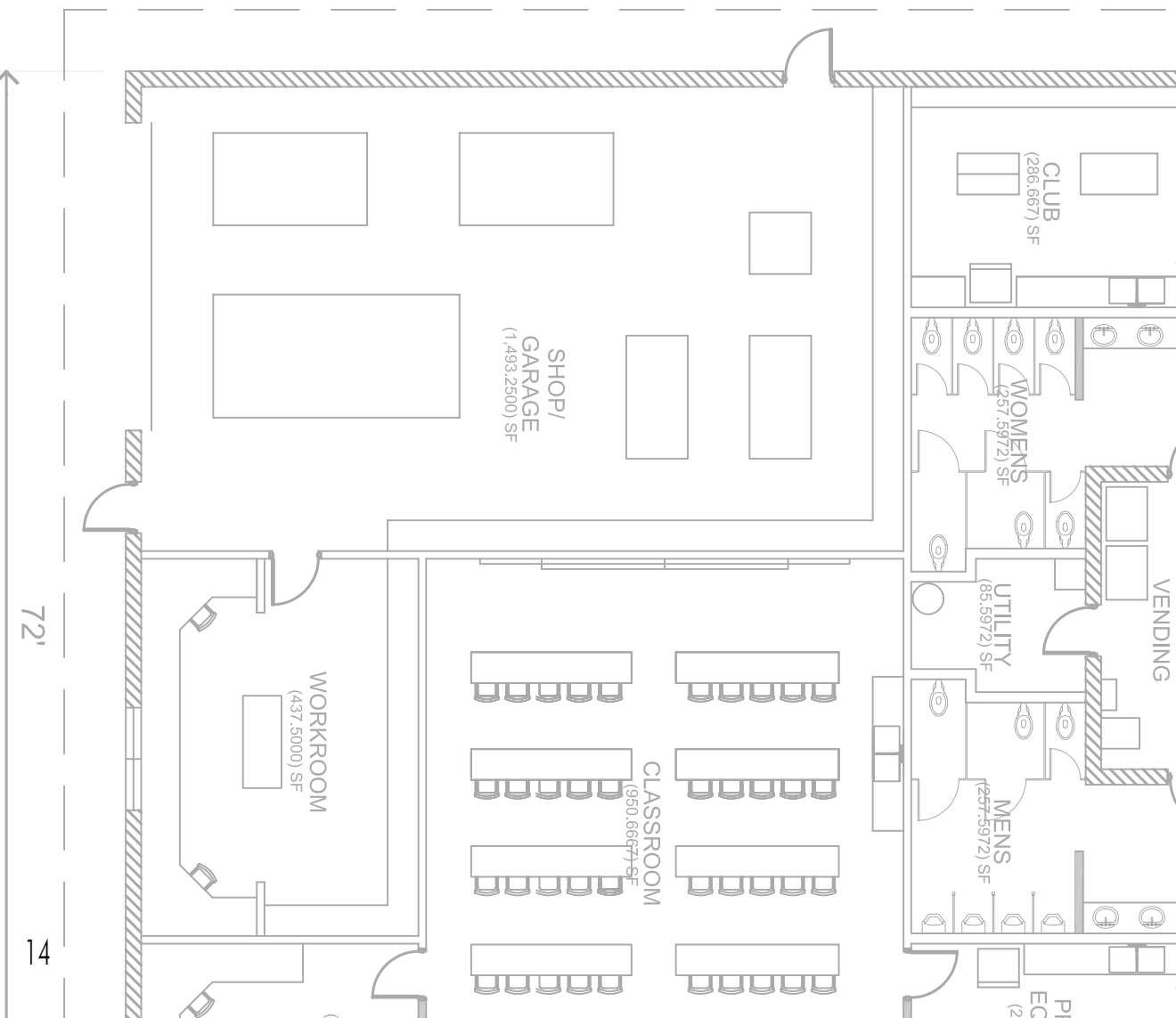

## Example Area Catalogs

Indoor Range page 15-17  
 Support Facility page 18-19  
 Site Area page 20

## Expanded Ideas Catalogs

Indoor Range page 21-24  
 Support Facility page 25-26  
 Site Area page 27

## Site Plans

Overall Site Plan page 28  
 Master Plan - Initial Phase page 29

## Field Plans

Youth Community Field page 30  
 Practice Field page 31  
 Field Course Templates page 32-33  
 Event Field page 34

## Building Plans

Support Facility Floor Plan page 35  
 Indoor Range Plan page 36  
 Indoor Facility Floor Plan page 37

## EXAMPLE INDOOR RANGE AREA CATALOG

Description	Width	Length	Area SF	Notes
<b>Indoor range and support areas</b>				<b>Multiple activities:</b>
Archers/Spectator area	112	50	5,600	Director of shooting area
Target lanes	112	100	11,200	Timers, PA speakers
Target area	112	10	1,120	Targets matts, stands, arrow curtian, plywood Introduction to archery and expos Beginner, intermediate and advance classes Practice, training and club sessions Instructor, coach and support staff development Competitions and tournaments
Bulk storage	24	92	2,208	Target matts and stands 3D targets Bow stands Chairs and tables Large equipment
Association	12	24	288	Club or other facility partner Equipment and storage Bow and arrow shop
Workshop	12	24	288	Bow and arrow tuning Workshop benches and tools
Program equipment storage	12	24	288	Bows, arrows, and accessories Teaching equipment
<b>Education and meetings</b>				
Classroom	30	32	960	Classroom education Multi media presentations
Classroom materials	6	12	72	Printed teaching materials Small teaching aids and devices
Meeting room	12	20	240	Conference room Visiting coach and administrators Multi media presentations
Kitchenette	10	12	120	Break room Snacks and beverages Catering serving area

## EXAMPLE INDOOR RANGE AREA CATALOG

Description	Width	Length	Area SF	Notes
<b>Operations and administration</b>				
Front desk	12	16	192	Customer check-in and check out Information and printed materials Indoor range supervision Daily operations
Technology equipment	10	12	120	Closed circuit video and recording Sound system Security and fire alarm equipment Network, internet and telephone Energy management system Other
Publications	8	12	96	Information and printed materials storage
Office storage	8	12	96	Supplies and files
Office equipment	8	12	96	Copier Supplies File cabinets Counter and cabinets
Administrator	12	16	192	Work station Files Visitor seating
Assistant/ intern	8	12	96	Work station
Manager	12	16	192	Work station Supervision Visitor seating
Head coach	12	16	192	Work station Teaching equipment Visitor seating
Instructor	12	16	192	Work station Files Visitor seating



## EXAMPLE INDOOR RANGE AREA CATALOG

Description	Width	Length	Area SF	Notes
<b>General areas</b>				
Outer lobby	20	24	480	Restrooms access Vending and drinking fountains
Inner lobby	20	24	480	Indoor range access Support area access Bulletin board and signage Information and display
Men's Restroom	16	26	416	Fixture count per governing code
Women's Restroom	16	26	416	Fixture count per governing code
Utility	8	12	96	Mop sink Cleaning supplies and equipment Water heating Electrical panels
Mechanical	12	24	288	A/C equipment Fire sprinkler supply riser Facility supplies Electrical service
<b>Subtotal</b>			26,024	Net area square footage
<b>Hallways and other</b>		2.61%	678	
<b>Total area</b>			26,702	To outside face of exterior walls

## EXAMPLE SUPPORT FACILITY AREA CATALOG

Description	Width	Length	Area SF	Notes
<b>Exterior space</b>				
Building overall area	72	72	5,184	
Patio	22	72	1,584	Gathering, benches and tables
Surrounding walks	8	260	2,080	Paved
Yard	90	180	16,200	Vehicles, equipment, storage Paved Fences, pedestrian and vehicle gates
<b>Exterior overall area</b>			25,048	Area square footage

## EXAMPLE SUPPORT FACILITY AREA CATALOG

Description	Width	Length	Area SF	Notes
<b>Support Facility Building</b>				
Men's Restroom	15	17	255	Fixture count per governing code
Women's Restroom	15	17	255	Fixture count per governing code
Utility	8	11	88	Mop sink Cleaning supplies and equipment Water heating Electrical panels
Classroom	30	32	960	Classroom education Multi media presentations
Program Equipment	14	20	280	Practice, training and club sessions Instructor, coach and support staff development Competitions and tournaments
Club (Association)	14	20	280	Club or other facility partner Equipment and storage Bow and arrow shop
Office	14	18	252	Administration and supervision Information and printed materials Workstation, visitor seating Files, supplies, office equipment
Workroom	18	24	432	Workshop benches, tools and storage Workstation, files, supplies, equipment
Shop Garage	30	50	1,500	Work benches, tools and storage Vehicles and garage door Water, electricity, ventilation Per governing codes
<b>Subtotal</b>			4,302	Net area square footage
<b>Other</b>		3.37%	145	
<b>Total area</b>			4,447	To outside face of exterior walls

## EXAMPLE SITE AREA CATALOG

Description	Width	Length	Subtotal	Quantity	Area Total	Notes
<b>Site areas</b>						
Entry and main drives	30	800	24,000	1	24,000	Entrance, vehicle gate for control Signage
Parking	10	35	350	350	122,500	10% accessible parking Per local governing codes
Drop off and pick up	30	250	7,500	2	15,000	Bow cases and equipment
Youth/community field	250	500	125,000	1	125,000	
Practice field	350	500	175,000	1	175,000	
Field course	150	290	43,500	14	609,000	Approximately 1 acre per field target
Event field	400	500	200,000	1	200,000	
Shared safety zones	66	500	33,000	(2)	(66,000)	Deduct for shared safety zone areas
Indoor range building footprint	150	250	37,500	1	37,500	
Support facility footprint	90	100	9,000	1	9,000	
Support facility yard	90	180	16,200	1	16,200	
<b>Subtotal</b>					1,267,200	
Landscaping and border spaces				10.0%	126,720	
Terrain						Topography varies
<b>Total area</b>			-		1,393,920	
				43,560	32	Acres

## EXPANDED IDEAS INDOOR RANGE CATALOG

Description	Width	Length	Area SF	Notes
<b>Indoor range and support areas</b>				<b>Multiple activities:</b>
Archers equipment area				Counter for bow cases, bow set up and take down
Spectators area				Spectator seating
Archers area				Archers seating
Director of shooting area				Desk, chair, timing control, PA system, music
Equipment area				Bow placement during events and programs
Waiting line				Area to wait immediately prior to shooting
<b>Shooting line</b>				
Target lanes	5.33			By distance, 18M, 25M, 30M, 50M, 70M, 90M 18M common indoor distance 25M offered internationally 30M minimum outdoor distance 50M compound bow distance 70M Olympic bow distance 90M maximum outdoor training distance 5'-4" per typical target matt and target stand Timers, PA speakers
Side of target clearance	4			Two feet each side of shooting line = 4 feet
Target area		10		Targets matts, stands, arrow curtain, plywood/MDF
Total range space				Allow for columns and obstructions, pad with foam or other soft energy absorbing material Uniform lighting level, 30 foot-candles, diffuse natural lighting Air conditioning Introduction to archery and expos
Uses				Beginner, intermediate and advance classes Practice, training and club sessions Instructor, coach and support staff development Competitions and tournaments
Mezzanine				For observation or as a target or shooting position
Expansion area				To increase the range size
<b>Range support</b>				
Range support office				Range manager, guest instructor or coach
Program Workshop				Bow and arrow tuning Workshop benches and tools

## EXPANDED IDEAS INDOOR RANGE CATALOG

Description	Width	Length	Area SF	Notes
Resource room				Video studio, editing, production
Publications				Information and printed materials storage
Office storage				Supplies and files
Office equipment				Copier Supplies File cabinets Counter and cabinets
Staff restroom				Staff use
Staff break room				Coffee, beverages, snacks, lunch
Administrator				Work station Files Visitor seating
Assistant/ intern				Work station
Manager				Work station Supervision Visitor seating
Head coach				Work station Teaching equipment Visitor seating
Instructor				Work station Files Visitor seating
<b>General areas</b>				
Entry Vestibule				Conditioned "air lock"
Lobby				Indoor range access Support area access Bulletin board and signage Information, display, pamphlets Restrooms access Drinking fountain
Vending area				Vending machines, beverages, snacks, fund raising
Men's Restroom				Fixture count per governing code
Women's Restroom				Fixture count per governing code

## EXPANDED IDEAS INDOOR RANGE CATALOG

Description	Width	Length	Area SF	Notes
Program equipment storage				Bows, arrows, and accessories Teaching equipment
Resource				Video studio, office, meeting, special use
Archers lockers				Private equipment storage
Bulk storage				Target mats and stands 3D targets Bow stands Chairs and tables Large equipment
<b>Associations, partners and clubs</b>				
Office				
Workroom				Bow and arrow shop
Equipment storage				Bows, arrows, and accessories
Education and meetings				
Classroom(s)				Classroom education Multi media presentations
Classroom materials				Printed teaching materials Small teaching aids and devices
Conference room				Visiting coach and administrators Multi media presentations Break room
Kitchenette				Snacks and beverages Catering serving area
<b>Operations and administration</b>				
Front desk				Customer check-in and check out Information and printed materials Indoor range supervision Closed circuit video and recording, indoors and outdoors Daily operations
Technology equipment				Closed circuit video and recording Sound system Security and fire alarm equipment Network, internet and telephone Energy management system

## EXPANDED IDEAS SUPPORT FACILITY CATALOG

Description	Width	Length	Area SF	Notes
<b>Support Facility Building</b>				
Men's Restroom				Fixture count per governing code
Women's Restroom				Fixture count per governing code
Utility				Mop sink Cleaning supplies and equipment Water heating Electrical panels
Classroom				Classroom education Multi media presentations
Program Equipment				Practice, training and club sessions Instructor, coach and support staff development Competitions and tournaments
Club (Association)				Club or other facility partner Equipment and storage Bow and arrow shop
Office				Administration and supervision Information and printed materials Workstation, visitor seating Files, supplies, office equipment
Rescource room				Video taping
Coach/Instructor				Office
Meeting room				Conference, small classroom
Partner office				Associate program
Workroom				Workshop benches, tools and storage Workstation, files, supplies, equipment
Shop Garage				Work benches, tools and storage Vehicles and garage door Water, electricity, ventilation Per governing codes
Other uses				See indoor range uses
<b>Subtotal</b>				Net area square footage
Other				
<b>Total area</b>				To outside face of exterior walls



## EXPANDED IDEAS INDOOR RANGE CATALOG

Description	Width	Length	Area SF	Notes
Utility				Mop sink Cleaning supplies and equipment Water heating Electrical panels
Facility storage				Building facility inventory (filters, light bulbs, materials)
Mechanical				A/C equipment Fire sprinkler supply riser Facility supplies Electrical service
<b>Other uses</b>				
Compatible programs				Sports, natural resource management, recreation Administration, multipurpose, part time uses
Tenant space				Lease space
Temporary				Seasonal uses
Retail				Archery related
Food concessions				Full time, part time, event specific
Preparation				
Food storage				
Supplies				
Restroom				
Serving				
Customer				
Stage				

## EXPANDED IDEAS SITE AREA CATALOG

Description	Width	Length	Subtotal	Quantity	Area Total	Notes
<b>Site areas</b>						
Entry and main drives						Entrance, vehicle gate for control Signage
Parking						10% accessible parking Per local governing codes
Drop off and pick up						Bow cases and equipment
Youth/community field						
Practice field						
Field course						Approximately 1 acre per field target
Event field						
Shared safety zones						Deduct for shared safety zone areas
Indoor range building footprint						
Support facility footprint						
Support facility yard						
Other						
Shared parking space						
Partner associations						
Retail/commerical						
Open space						
Flood plain						Border area
Solar/Wind farm						
Agricultural						
Retired landfill						
Special events						Fairs and carnivals
Camping						Tent and RV
Picnic area						
Recreation						Hiking/Fishing
Subtotal						
Landscaping and border spaces						
Terrain						Topography varies
<b>Total area</b>				43,560		43,560 square feet per acre

## EXPANDED IDEAS SUPPORT FACILITY CATALOG

Description	Width	Length	Area SF	Notes
<b>Exterior space</b>				
Building overall area				
Patio				Gathering, benches and tables Shade and rain cover
Surrounding walks				Paved
Yard				Vehicles, equipment, storage Paved Fences, pedestrian and vehicle gates
<b>Exterior overall area</b>				Area square footage

## OVERALL SITE PLAN



1540.00'  
[469.39M]

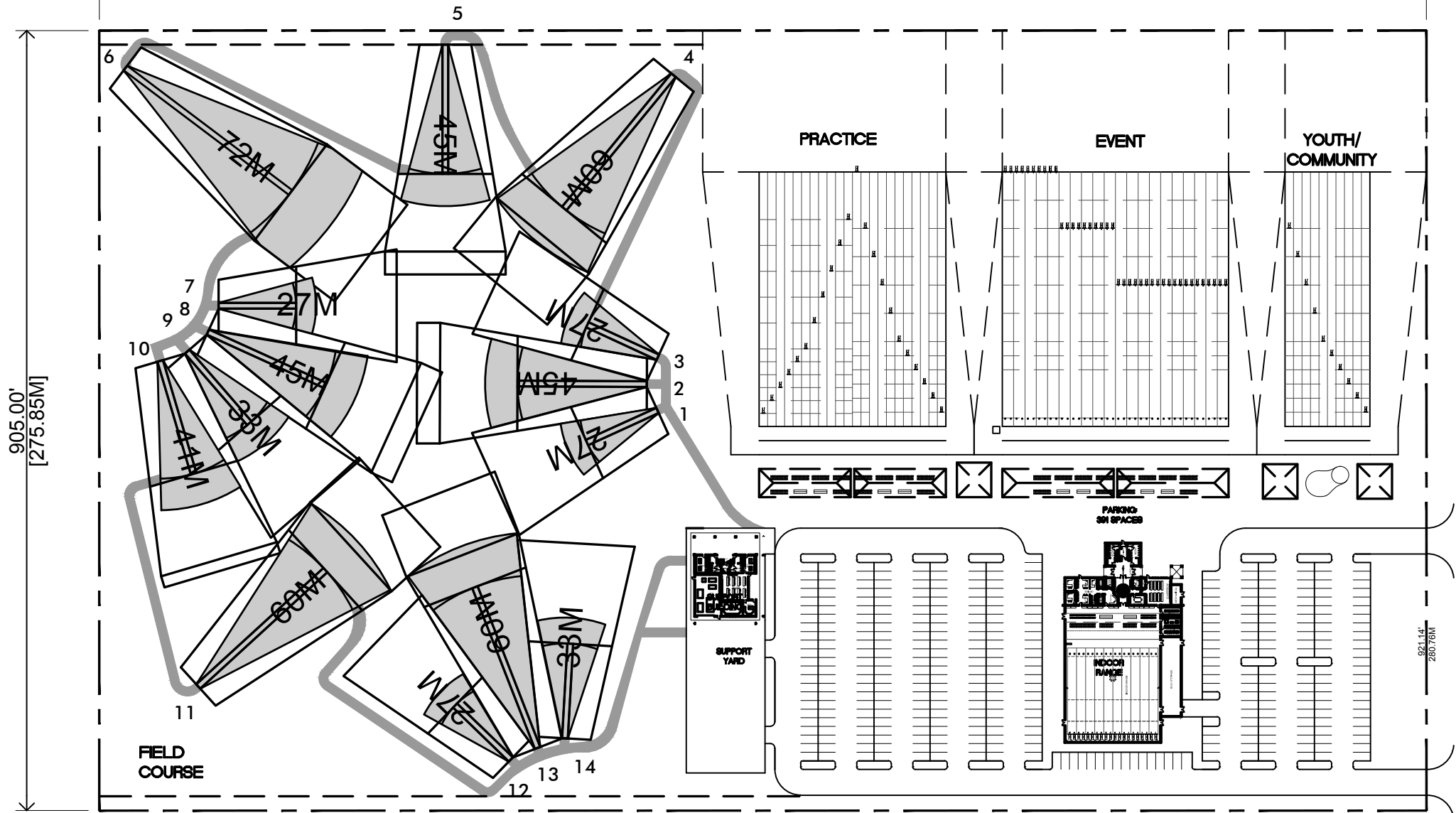

25m 50m 75m 125m

SCALE

## MASTER PLAN - INITIAL PHASE

1540.00'  
[469.39M]

Example Initial Development  
"Community Archery Park"

COMMUNITY  
ARCHERY PARK

EVENT

YOUTH/  
COMMUNITY

905.00'  
[275.85M]

PARKING  
501 SPACES

SUPPORT  
YARD

INDOOR  
RANGE

921.14'  
280.76M

FIELD  
COURSE

## YOUTH/COMMUNITY FIELD

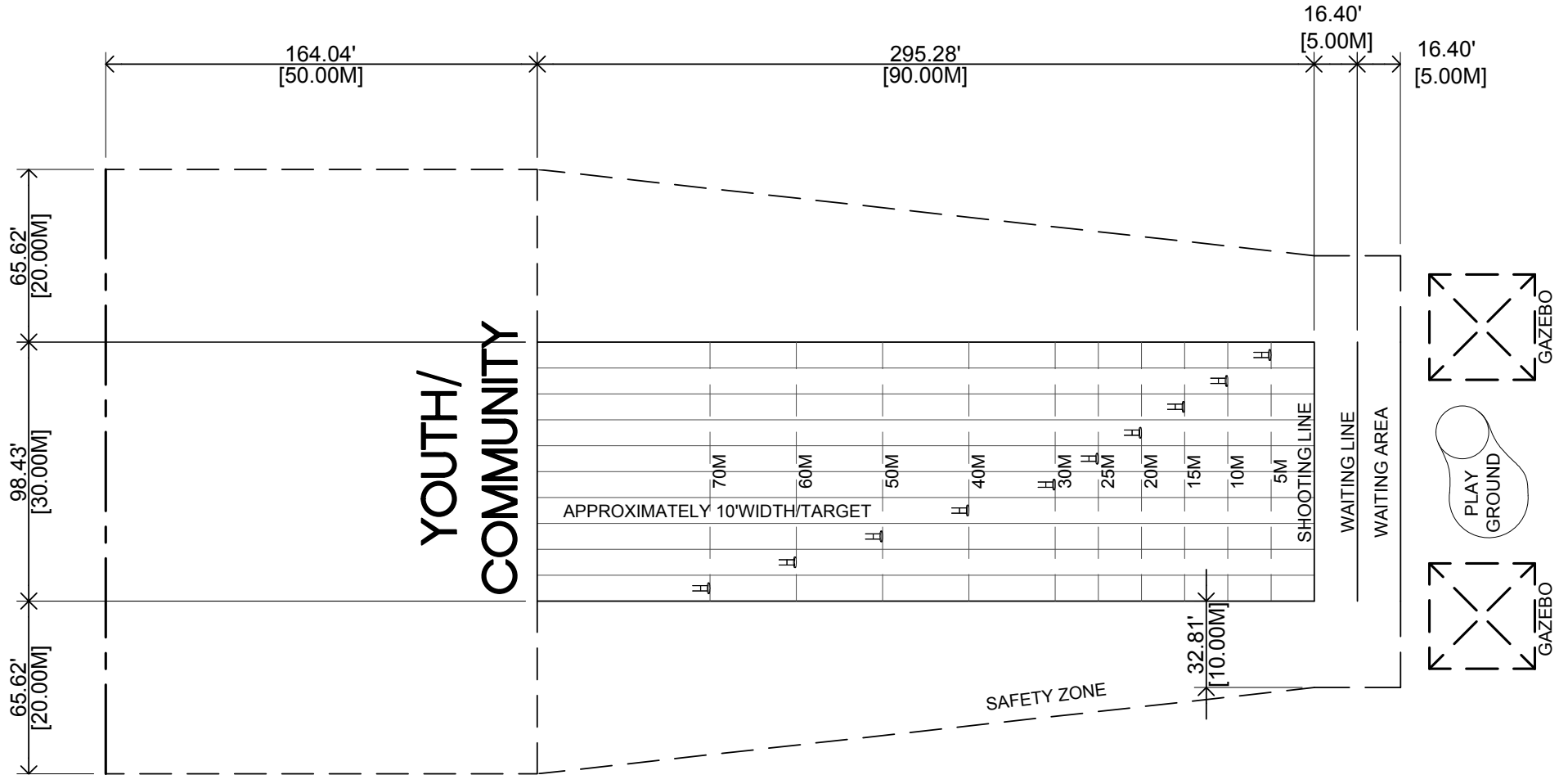
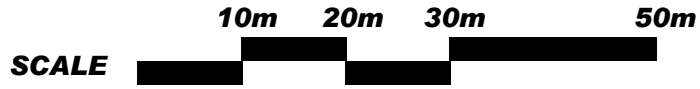

## PRACTICE FIELD

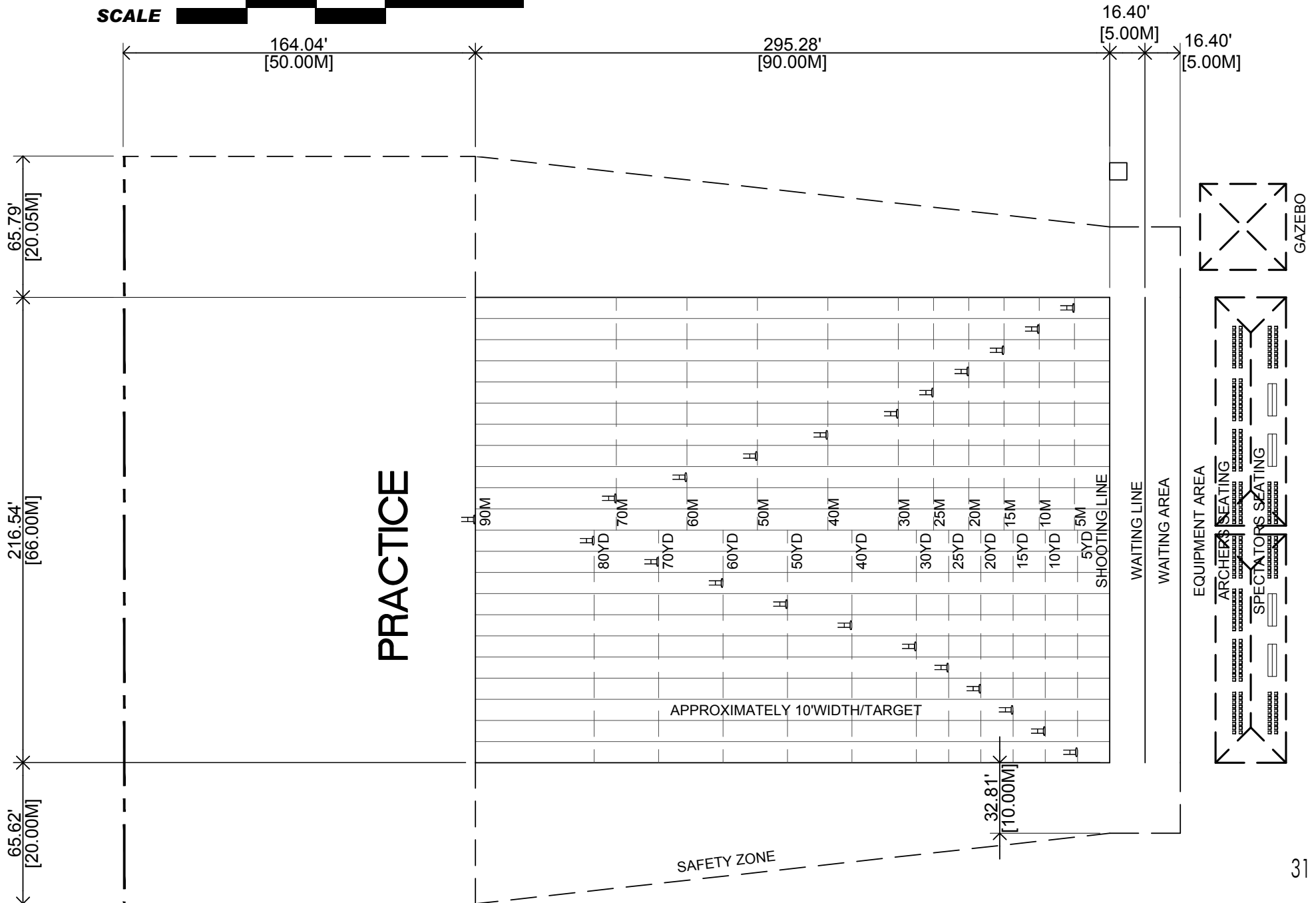

## FIELD COURSE TEMPLATES

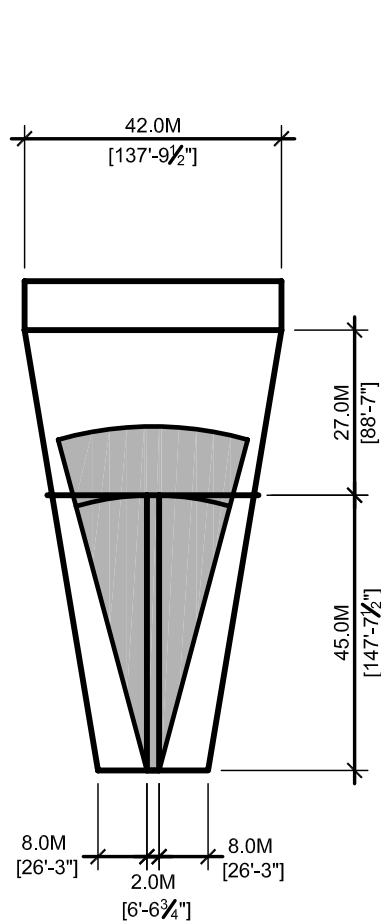

45 METER RANGE  
50 YARDS RANGE  
(QTY. OF 3)

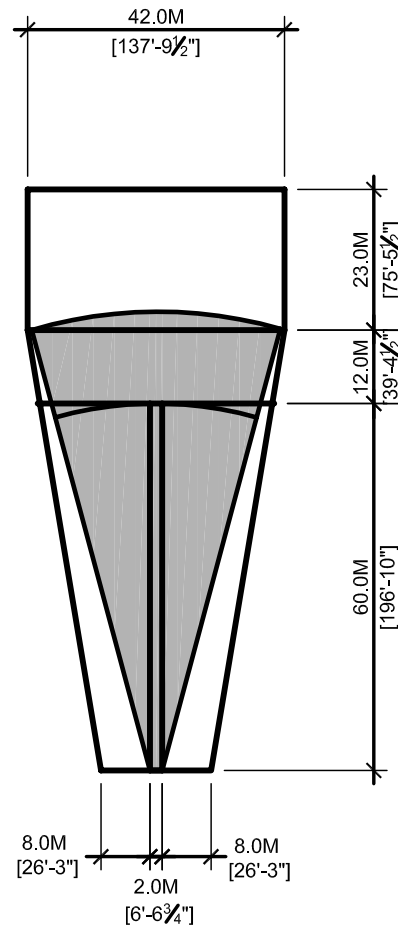

60 METER RANGE  
66 YARDS RANGE  
(QTY. OF 3)

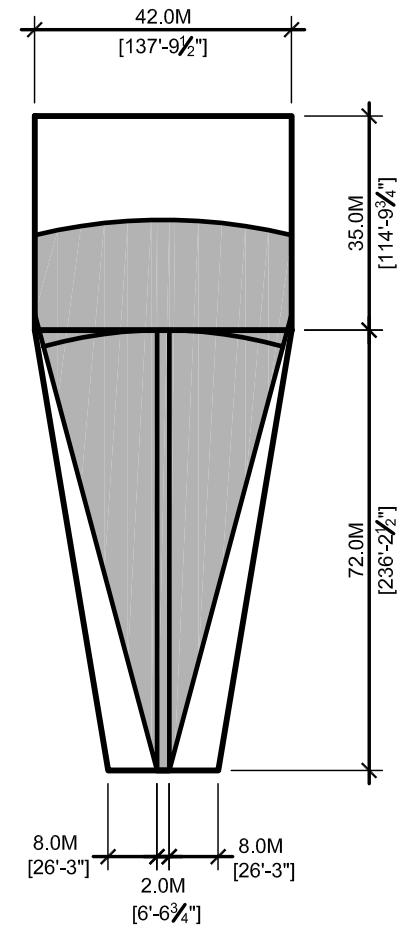

72 METER RANGE  
80 YARDS RANGE  
(QTY. OF 1)



## FIELD COURSE TEMPLATES

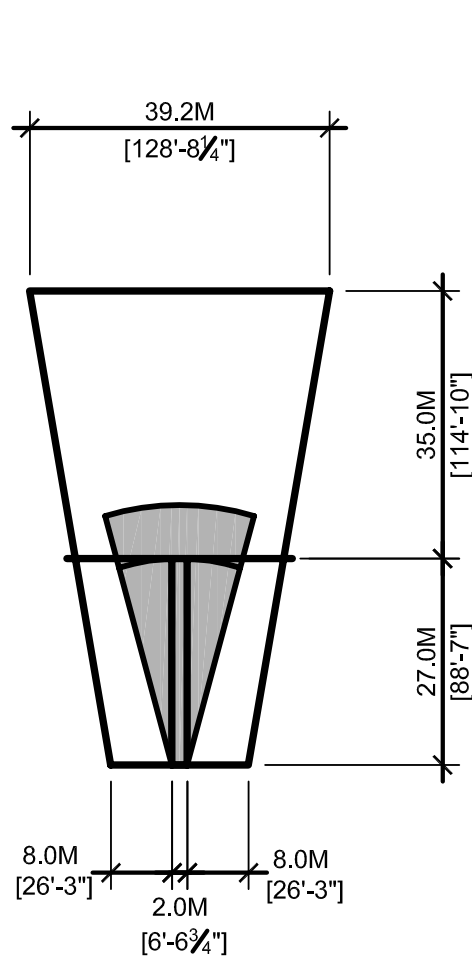

27 METER RANGE  
30 YARDS RANGE  
(QTY. OF 4)

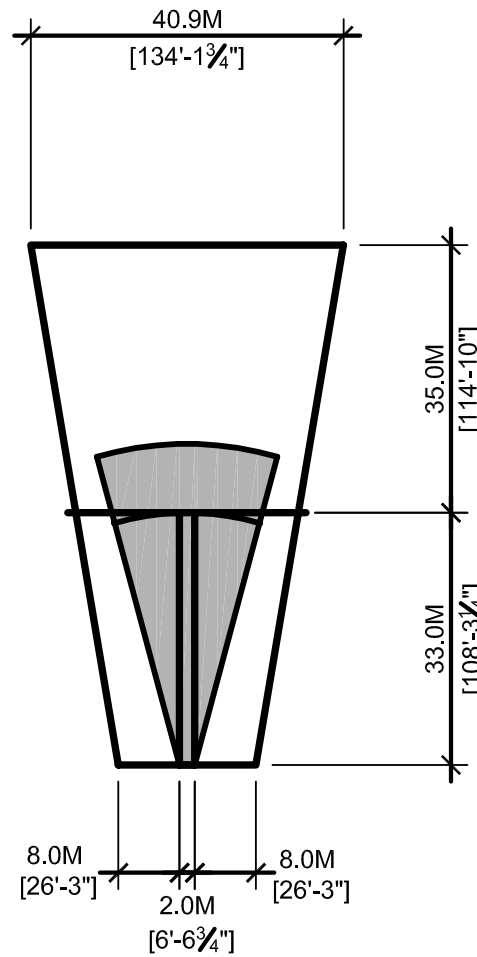

33 METER RANGE  
36 YARDS RANGE  
(QTY. OF 2)

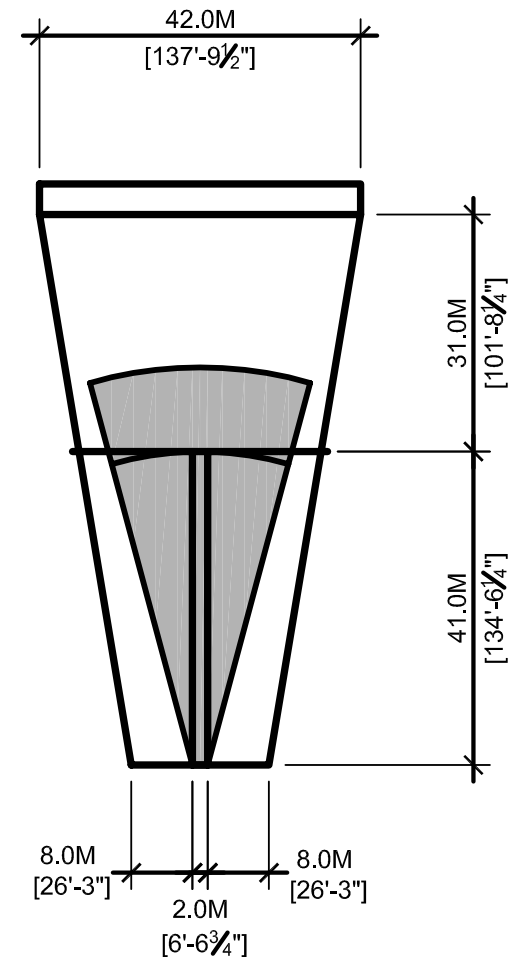

41 METER RANGE  
45 YARDS RANGE  
(QTY. OF 1)

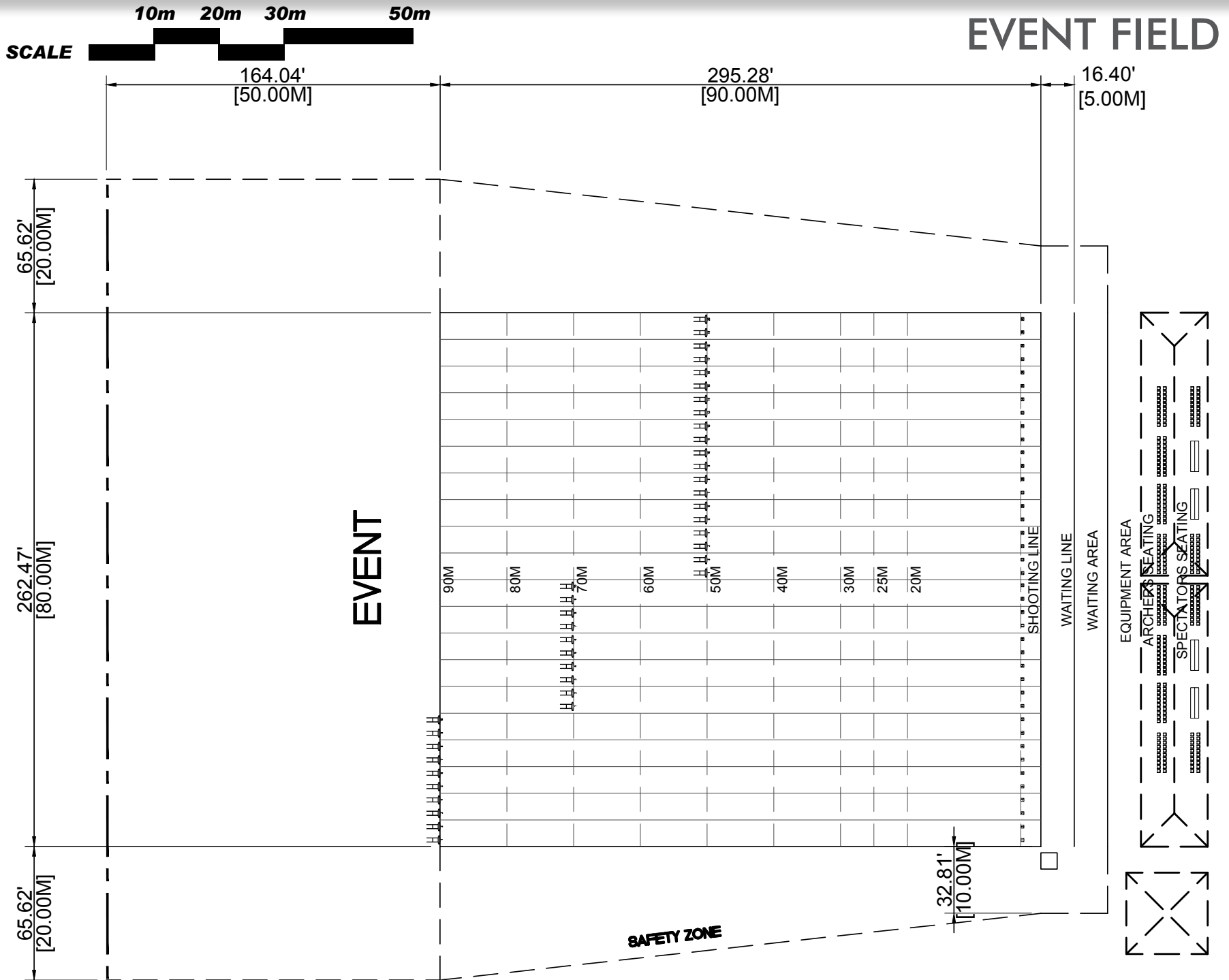

## SUPPORT FACILITY FLOOR PLAN

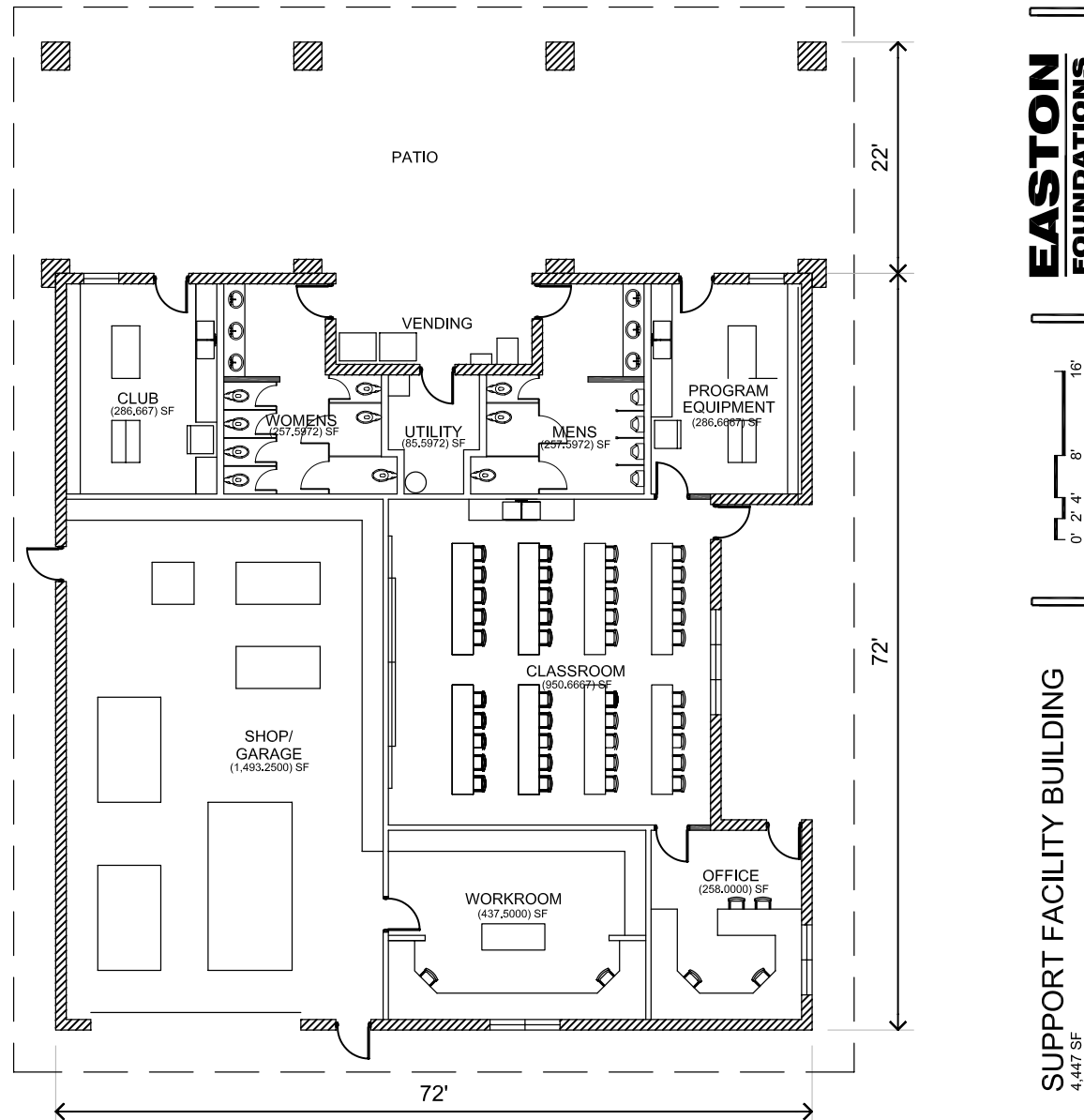



## INDOOR RANGE PLAN

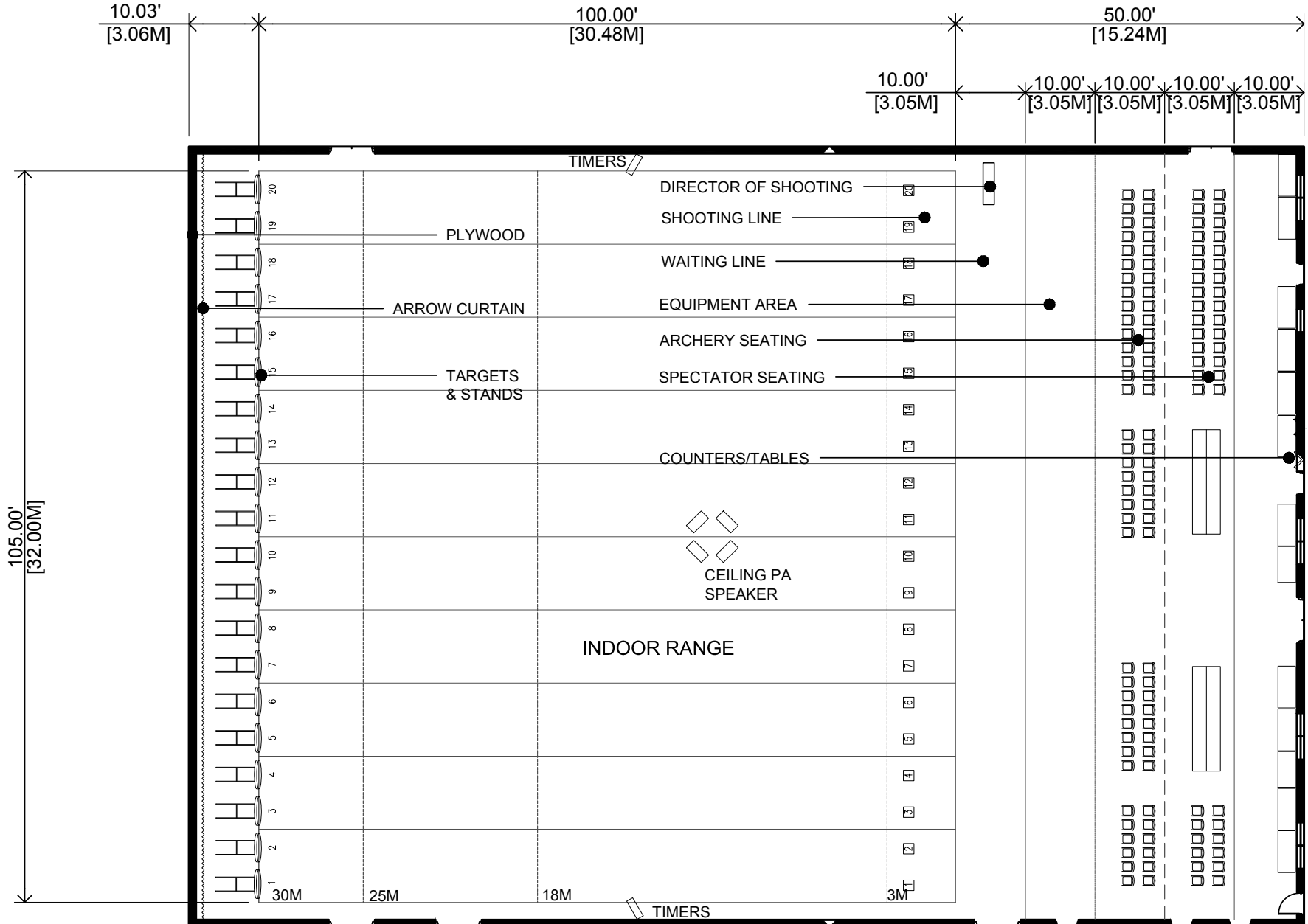

## INDOOR FACILITY FLOOR PLAN

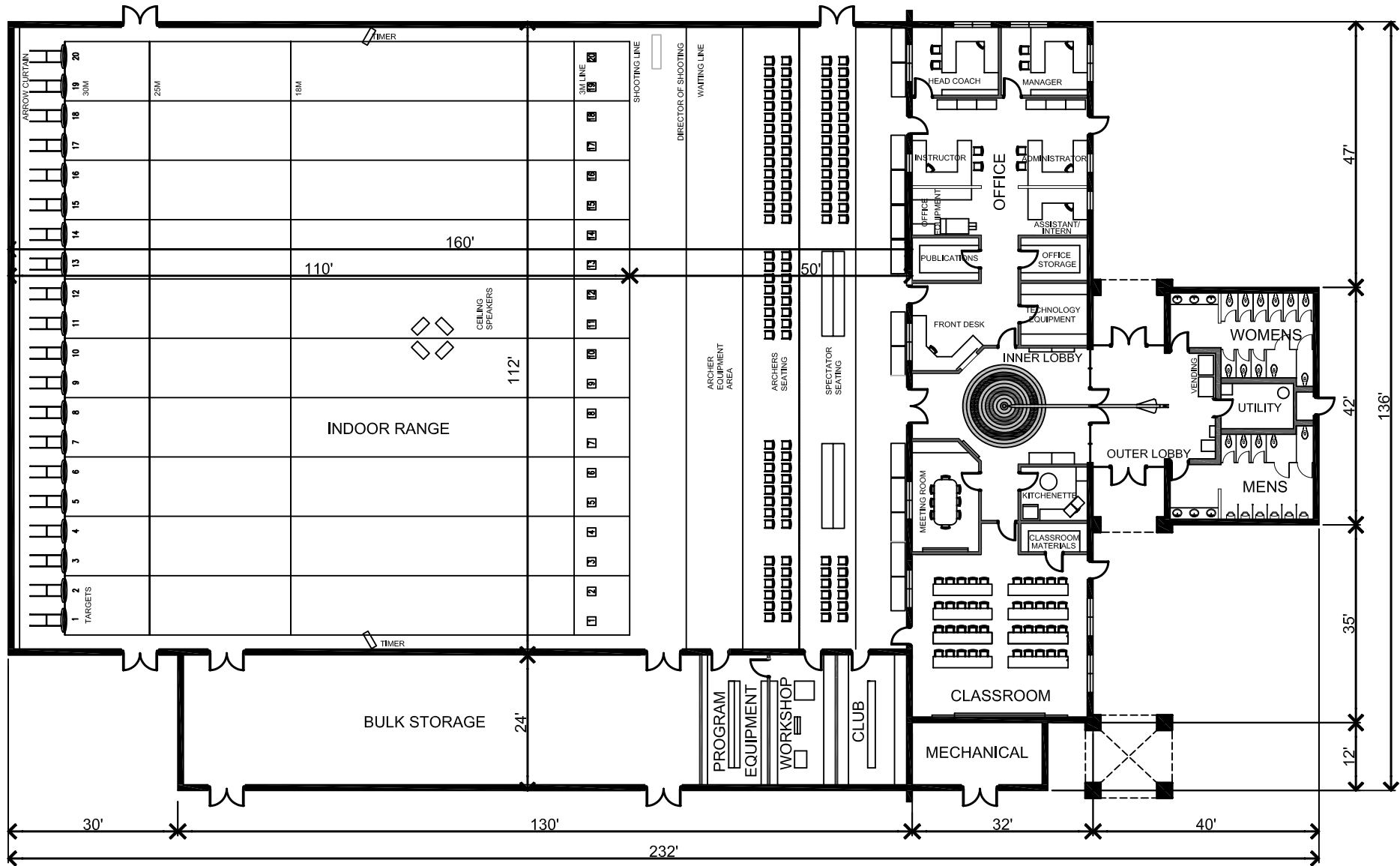

## ARCHERY FACILITY CATEGORIES

The Easton Foundations has prepared this Archery Facility Planning Guide to help local planners develop archery facilities in their communities. It is the Foundation's goal to have many centers operate around the country to train archery athletes and coaches, and to provide fun community archery activities.

As you plan the size and amenities of your facility, here are some category guidelines as to the types of activities each size can potentially serve. These categories are also listed on the [www.esdf.org](http://www.esdf.org) website. The Easton Foundations accepts grant applications requesting assistance in funding the construction of archery facilities. Agencies requesting grant funding are measured against these categories as part of the grant review.

### Archery Center General Requirements (for all types of centers)

- A strong local 501(c)3 organization, university, school, state, or local government as a development and operating partner at each facility (we also expect them to have a proven record of financial stability).
- Strong community support (City, County, State & Department of Fish & Wildlife), financial commitments, and in-kind contributions to the project.
- An existing base of local archery activities near a major population center (with several universities within one hour drive) with the potential to expand youth, interscholastic, and collegiate archery participation.
- Partners that are willing to help support the facility through a matching grant program with the Easton Foundations.

### Activities by Type of Center

#### *Local Club or Recreation Department Facility*

- Support of archery – practice ranges.
- Training facilities – indoor and/or outdoor shooting ranges.
- Desirable to have archery training and transition programs.
- Ability to track and report archer progress to National CHAMPS database of National Head Coach and USAA is desirable.
- Local archery activities.
- A plan to expand existing youth programs.

#### *Community Archery Facility*

- Support of archery – Olympic-style practice field; Field & 3-D Courses, and Bowhunting ranges.
- Training facilities – indoor and/or outdoor shooting ranges.
- Archery training and transition programs (program progression through NASP, ASAP, JOAD, OAS, College Archery Program,).
- Archer progress tracked & reported to National CHAMPS database of National Head Coach and USAA.
- Near large population center.
- Near College or University with College Archery Program potential.
- Regional & Local archery activities.
- A plan to expand existing interscholastic & collegiate programs.

## ***Archery Center***

- Support all styles of archery – Olympic-style training, practice & competition fields; Field & 3-D Courses, and Bowhunting ranges.
- Year round training facilities – indoor & outdoor shooting ranges required.
- Archery training and transition programs with an Olympic-style archery goal (program progression through NASP, ASAP, JOAD, OAS, Dream Team, College Archery Program, Olympic Team, Resident Athletes)
- Archer progress tracked & reported to National CHAMPS database of National Head Coach and USAA.
- Near major population center.
- Near major College or University (within 1-hour drive) with sports medicine capabilities, and College Archery Program potential.
- National, Regional & Local archery activities.
- A plan to expand existing youth, interscholastic & collegiate programs.

## ***Archery Center of Excellence***

- Major facilities that have all the requirement of (3) above.
- A center that will be a regional center for other archery centers.
- A center that will have a 70 meter indoor range that will accommodate 10 targets.
- A center that has frequent visits from coaches associated with the USAA Archery Center of Excellence
- A center with adjacent or near-by outdoor 90 meter range to hold team trials and other USAA competitions.
- A center with tournament timing and scoring equipment to use on site or to loan out to tournament organizers in the region.
- Any future Foundation requirements to become an Archery Center of Excellence.

The Easton Foundations only provides partial funding for most projects and requires use of city or state property and/or buildings and matching funds.

In your grant application please explain how your group will address these issues and meet the Easton Foundation objectives listed above and also detailed on the grant application form. Grant application forms are available of the Easton Foundations website.

## **Partner with an Archery Organization(s)**

It is also recommended you partner with one or more national archery organizations, or state affiliate, in planning the facility and its programming. These individuals and organizations can provide you with specific needs of potential events and activities that may have a bearing on your facility design.

Visit [www.DiscoverArchery.org](http://www.DiscoverArchery.org) to learn more about archery and it's many activities, and the organizations that manage it.

*ESDF (Easton Sports Development Foundation) is committed to develop competitive Olympic-style archery efforts that create a clear path for skilled young archers to reach the goal of being an Olympic champion. ESDF supports programs that develop improved skills as archers progress through Olympic Archery in the Schools, Junior Olympic Archery Development, middle and high schools, colleges, and the USA National Olympic Team training programs. To this end we offer programs, resources and grants.*

*For more information,*



7855 Haskell Avenue, Suite 360  
Van Nuys, CA 91406  
Main Phone: (818) 787-2800  
Fax: (818) 782-7625

Grant Application Forms  
Digital Facility Planning Guide  
Facility Case Studies

[www.esdf.org](http://www.esdf.org)